

## The 5-Deoxy-5-methylthio-xylofuranose Residue in Mycobacterial Lipoarabinomannan. Absolute Stereochemistry, Linkage Position, Conformation, and Immunomodulatory Activity

Maju Joe,<sup>†</sup> Daniel Sun,<sup>†</sup> Hashem Taha,<sup>†</sup> Gladys C. Completo,<sup>†</sup> Joanne E. Croudace,<sup>‡</sup> David A. Lammas,<sup>‡</sup> Gurdyal S. Besra,<sup>§</sup> and Todd L. Lowary<sup>\*,†</sup>

Contribution from the Alberta Ingenuity Centre for Carbohydrate Science and Department of Chemistry, The University of Alberta, Gunning-Lemieux Chemistry Centre Edmonton, Alberta, T6G 2G2 Canada, Medical Research Council Centre for Immune Regulation, Birmingham Medical School, Birmingham University, Edgbaston, Birmingham, B15 2TT, U.K., and School of Biosciences, University of Birmingham, Edgbaston, Birmingham B15 2TT, U.K.

Received October 28, 2005; E-mail: tlowary@ualberta.ca

**Abstract:** Mycobacteria produce a cell-surface glycoconjugate, lipoarabinomannan (LAM), which has been shown to be a potent modulator of the immune response that arises from infection by these organisms. Recently, LAM from the human pathogens *Mycobacterium tuberculosis* and *M. kansasii* has been shown to contain an unusual 5-deoxy-5-methylthio-xylofuranose (MTX) residue as well as its corresponding oxidized counterpart, 5-deoxy-5-methylsulfoxy-xylofuranose (MSX). To date, the absolute configuration of these residues and their linkage position to the polysaccharide are unknown, as is their biological role. Through the combined use of chemical synthesis and NMR spectroscopy, we have established that the MTX/MSX residues in these glycoconjugates are of the D-configuration and that they are linked  $\alpha$ -(1 $\rightarrow$ 4) to a mannopyranose residue in the mannan portion of the glycan. Conformational analysis of the MTX/MSX residue using NMR spectroscopy showed differences in ring conformation and as well as in the rotamer populations about the C-4–C-5 bond, as compared to the parent compound, methyl  $\alpha$ -D-xylofuranoside. Two of the synthesized disaccharides, **3** and **34**, were tested in cytokine induction assays, and neither led to the production of TNF- $\alpha$  or IL-12p70. In contrast, both demonstrated modest inhibitory properties when these same cytokines were induced using a preparation of Interferon- $\gamma$  and *Staphylococcus aureus* Cowan strain (SAC/IFN- $\gamma$ ). These latter observations suggest that this motif may play a role in the immune response arising from mycobacterial infection.

### Introduction

Tuberculosis (TB) is the world's most lethal bacterial disease, killing more than 2 million people worldwide each year.<sup>1–3</sup> Increased recent concern about the impact of this disease on world health has resulted from the emergence<sup>4</sup> of multidrug resistant strains of *Mycobacterium tuberculosis*, the organism that causes the disease, and difficulties in treating individuals who have both TB and HIV.<sup>5</sup> A hallmark of TB and other mycobacterial diseases is the need for protracted treatments, typically involving multiple antibiotics that must be taken over several months.<sup>6</sup> The need for this prolonged drug regimen is due to the unusual structure<sup>7,8</sup> of the mycobacterial cell wall,

which serves as a formidable barrier to the passage of antibiotics into the organism. In addition to its role as a permeability barrier, it is now well-documented that mycobacterial cell wall components act as immunomodulatory molecules, enabling the organism to resist the immune system of the human host.<sup>9,10</sup>

The mycobacterial cell wall is rich in polysaccharides and lipids.<sup>7,8</sup> Among the many components that make up this protective structure, the largest is an immense glycoconjugate, the mycolyl-arabinogalactan-peptidoglycan (mAGP) complex, which is the major permeability barrier of the cell wall. Also present in this macrostructure is another glycoconjugate, lipoarabinomannan (LAM), a major antigenic species. Mycobacterial LAM has been implicated in a large, and increasing, number of important immunological events.<sup>9,10</sup> For example, in the case of *M. tuberculosis*, it is believed that this polysaccharide is of critical importance in allowing the organism to survive in host macrophages.

<sup>†</sup> The University of Alberta.

<sup>‡</sup> Birmingham University.

<sup>§</sup> University of Birmingham.

(1) Paolo, W. F., Jr.; Nosanchuk, J. D. *Lancet Infect. Dis.* **2004**, *4*, 287–293.

(2) Kremer, L.; Besra, G. S. *Expert Opin. Invest. Drugs* **2002**, *11*, 153–157.

(3) Coker, R. J. *Trop. Med. Int. Health* **2004**, *9*, 25–40.

(4) Nachega, J. B.; Chaisson, R. E. *Clin. Infect. Dis.* **2003**, *36*, S24–S30.

(5) De Jong, B. C.; Israelski, D. M.; Corbett, E. L.; Small, P. M. *Annu. Rev. Med.* **2004**, *55*, 283–301.

(6) Bass, J. B., Jr.; Farer, L. S.; Hopewell, P. C.; O'Brien, R.; Jacobs, R. F.; Ruben, F.; Snider, D. E.; Thornton, G. *Am. J. Respir. Crit. Care Med.* **1994**, *149*, 1359–1374.

(7) Brennan, P. J. *Tuberculosis* **2003**, *83*, 91–97.

(8) Lowary, T. L. *Mycobacterial Cell Wall Components*. In *Glycoscience: Chemistry and Chemical Biology*; Fraser-Reid, B., Tatsuta, K., Thiem, J., Eds.; Springer-Verlag: Berlin, 2001; pp 2005–2080.

(9) Nigou, J.; Gilleron, M.; Puzo, G. *Biochimie* **2003**, *85*, 153–166.

(10) Briken, V.; Porcellii, S. A.; Besra, G. S.; Kremer, L. *Mol. Microbiol.* **2004**, *53*, 391–403.

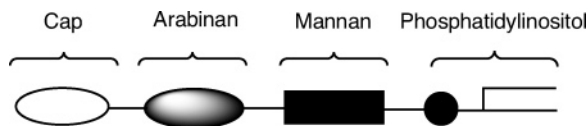

**Figure 1.** Schematic representation of the major structural domains in mycobacterial LAM.

The fine structure of mycobacterial LAM is generally well understood (Figure 1).<sup>9,10</sup> At its core is a phosphatidylinositol moiety to which is attached a mannan consisting of  $\alpha$ -(1 $\rightarrow$ 6) and  $\alpha$ -(1 $\rightarrow$ 2)-linked mannopyranose residues. An arabinan domain, composed of  $\alpha$ -(1 $\rightarrow$ 5),  $\alpha$ -(1 $\rightarrow$ 3), and  $\beta$ -(1 $\rightarrow$ 2)-linked arabinofuranose residues, is attached to the mannan chain. This arabinan is often further functionalized at its nonreducing terminus with “capping” motifs of varying structure. In *M. tuberculosis*, *M. bovis*, and *M. avium*, the predominant capping motifs are small  $\alpha$ -(1 $\rightarrow$ 2)-linked mannopyranosyl oligosaccharides, which, when present, give rise to a LAM variant termed ManLAM.<sup>11,12</sup> In contrast, in *M. smegmatis*, these mannose caps are replaced with inositol phosphate moieties providing a glycoconjugate called PILAM.<sup>13</sup> At least some of the immunomodulatory role of LAM has been ascribed to these capping motifs.<sup>9,10</sup>

Over the past several years, the structures of LAM molecules from a range of mycobacteria and other actinomycetes have been reported<sup>14–24</sup> and an impressive range of structural diversity has been identified. Among these was the discovery that LAMs from a number of *M. tuberculosis* strains contain a 5-deoxy-5-methylthio-pentose residue. To date, this substituent has been identified in both laboratory strains (H37Rv<sup>25</sup> and H37Ra<sup>25</sup>), as well as clinical isolates (CSU20<sup>25</sup> and MT103<sup>26</sup>) of *M. tuberculosis*. In the initial report describing this modification,<sup>25</sup> its stereochemical identity was not elucidated, but it was demonstrated that this motif is found linked to the mannopyranose capping residues. More recent work<sup>27</sup> established that this motif is a 5-deoxy-5-methylthio- $\alpha$ -xylofuranose (MTX) residue, but neither the absolute configuration (D vs L) nor the

attachment site to the LAM was determined. This moiety has also been found in *M. kansasii*, where it is attached not to the mannopyranose capping residues but rather to the mannan core.<sup>28</sup> In addition to MTX, the corresponding sulfoxide, 5-deoxy-5-methylsulfoxy-xylofuranose (MSX), is also present in these polysaccharides. The oxidation of MTX to MSX appears not to be an enzymatic process because a 1:1 ratio of diastereomeric sulfoxides is found.

The biological function of the MTX residue in LAM has not been established, nor has the biosynthetic pathway by which it is introduced into the polysaccharide. However, its distribution across a range of mycobacterial strains suggests that it has an important biological role. It is therefore of interest to determine the absolute stereochemistry of this residue and to establish its linkage to the polysaccharide. Furthermore, efficient access to MTX-containing fragments of LAM is important as such compounds will be of great use in studies focused on understanding the biological role of this motif. Described here is the synthesis of a panel of MTX- and MSX-containing disaccharides, which were used in NMR studies to demonstrate that these monosaccharides have the D-configuration and that they are attached to LAM via an  $\alpha$ -(1 $\rightarrow$ 4)-linkage to a mannopyranose residue. In addition, we have probed the conformation of the MTX/MSX substituent and tested the ability of two of the synthesized disaccharides to induce or suppress cytokine production.

## Results and Discussion

**Approach.** Through NMR spectroscopic investigations on <sup>13</sup>C-labeled LAM from *M. tuberculosis* H37Ra, Treumann et al. proposed that the MTX residue is linked to the mannopyranose capping units.<sup>25</sup> As part of these studies, an HMBC experiment was carried out showing a correlation between the anomeric hydrogen resonance of the MTX residue and a signal at 77.0 ppm in the <sup>13</sup>C NMR spectrum. Similarly, the anomeric carbon resonance of the MTX residue correlated with a signal at 3.77 ppm in the <sup>1</sup>H NMR spectrum. These data suggest that the linkage of the MTX to the mannose caps is via a secondary hydroxyl group. Therefore, we selected as targets disaccharides 1–6 (Chart 1), which contain either a D- or L-MTX residue (1–3 and 4–6, respectively) in an  $\alpha$ -linkage to one of the three secondary hydroxyl groups of methyl  $\alpha$ -D-mannopyranoside. We reasoned that after the synthesis of these six disaccharides, comparison of their NMR data with that reported for this residue in the native polysaccharide would allow us to establish not only the absolute configuration of this modified pentose but also its linkage position to the polysaccharide.

**Synthesis.** To synthesize these targets, we developed a strategy in which the methylthio group would be introduced near the end of the synthesis. This approach required the preparation of a series of six protected disaccharides with a leaving group at the primary position of the xylofuranose residue. We envisioned that the five building blocks shown in Chart 2 (7–11) could be used to assemble disaccharides 1–6. Mannopyranosides 9–11 are known compounds and were prepared as previously described.<sup>29</sup> The tosylated thioglycosides

- (11) Nigou, J.; Gilleron, M.; Cahuzac, B.; Bounery, J. D.; Herold, M.; Thurnher, M.; Puzo, G. *J. Biol. Chem.* **1997**, *272*, 23094–23103.
- (12) Khoo, K.-H.; Tang, J. B.; Chatterjee, D. *J. Biol. Chem.* **2001**, *276*, 3863–3871.
- (13) Khoo, K.-H.; Dell, A.; Morris, H. R.; Brennan, P. J.; Chatterjee, D. *J. Biol. Chem.* **1995**, *270*, 12380–12389.
- (14) Guéardel, Y.; Maes, E.; Ellass, E.; Leroy, Y.; Timmerman, P.; Besra, G. S.; Loch, C.; Strecker, G.; Kremer, L. *J. Biol. Chem.* **2002**, *277*, 30635–30648.
- (15) Torrelles, J. B.; Khoo, K.-H.; Sieling, P. A.; Modlin, R. L.; Zhang, N.; Marques, A. M.; Treumann, A.; Rithner, C. D.; Brennan, P. J.; Chatterjee, D. *J. Biol. Chem.* **2004**, *279*, 41227–41239.
- (16) Gibson, K. J. C.; Gilleron, M.; Constant, P.; Puzo, G.; Nigou, J.; Besra, G. S. *Biochem. J.* **2003**, *372*, 821–829.
- (17) Gibson, K. J. C.; Gilleron, M.; Constant, P.; Brando, T.; Puzo, G.; Besra, G. S.; Nigou, J. *J. Biol. Chem.* **2004**, *279*, 22973–22982.
- (18) Gibson, K. J. C.; Gilleron, M.; Constant, P.; Puzo, G.; Nigou, J.; Besra, G. S. *Microbiology* **2003**, *149*, 1437–1445.
- (19) Garton, N. J.; Gilleron, M.; Brando, T.; Dan, H.-H.; Giguère, S.; Puzo, G.; Prescott, J. F.; Sutcliffe, I. C. *J. Biol. Chem.* **2002**, *277*, 31722–31733.
- (20) Gilleron, M.; Garton, N. J.; Nigou, J.; Brando, T.; Puzo, G.; Sutcliffe, I. C. *J. Bacteriol.* **2005**, *187*, 854–861.
- (21) Sutcliffe, I. C. *Antonie Van Leeuwenhoek* **2000**, *78*, 195–201.
- (22) Flaherty, C.; Sutcliffe, I. C. *Syst. Appl. Microbiol.* **1999**, *22*, 530–533.
- (23) Flaherty, C.; Minnikin, D. E.; Sutcliffe, I. C. *Zentralbl. Bakteriologie* **1996**, *285*, 11–19.
- (24) Gibson, K. J. C.; Gilleron, M.; Constant, P.; Sichi, B.; Puzo, G.; Besra, G. S.; Nigou, J. *J. Biol. Chem.* **2005**, *280*, 28347–28356.
- (25) Treumann, A.; Feng, X.; McDonnell, L.; Derrick, P. J.; Ashcroft, A. E.; Chatterjee, D.; Homans, S. W. *J. Mol. Biol.* **2002**, *316*, 89–100.
- (26) Ludwiczak, P.; Gilleron, M.; Bordat, Y.; Martin, C.; Gicquel, B.; Puzo, G. *Microbiology* **2002**, *148*, 3029–3037.
- (27) Turnbull W. B.; Shimizu, K. H.; Chatterjee, D.; Homans, S. W.; Treumann, A. *Angew. Chem., Int. Ed.* **2004**, *43*, 3918–3922.

(28) Guéardel, Y.; Maes, E.; Briken, V.; Chirat, F.; Leroy, Y.; Loch, C.; Strecker, G.; Kremer, L. *J. Biol. Chem.* **2003**, *278*, 36637–36651.

(29) 9: Nashed, M. A.; Anderson, L. *Tetrahedron Lett.* **1976**, 3503–3506. 10, 11: Koto, S.; Takenaka, K.; Morishima, N.; Sugimoto, A.; Zen, S. *Bull. Chem. Soc. Jpn.* **1984**, *57*, 3603–3604.

Chart 1

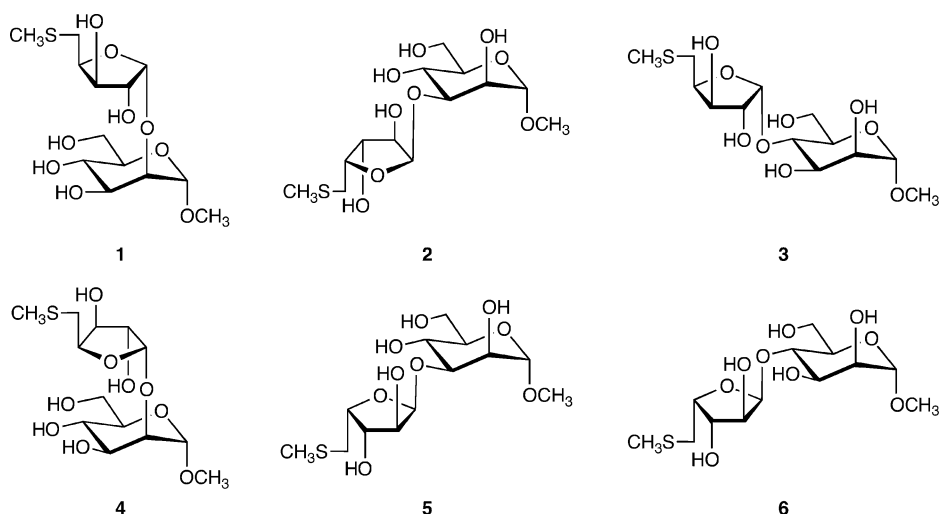
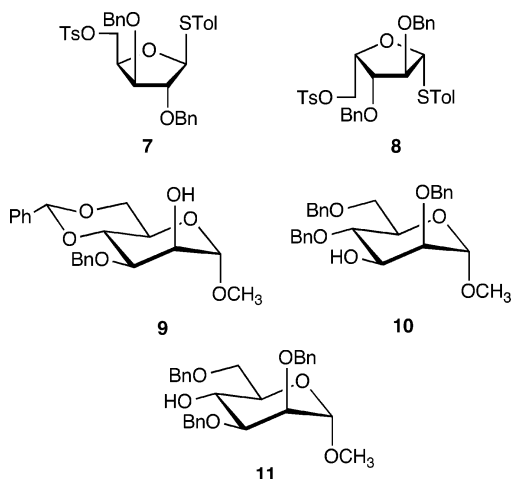
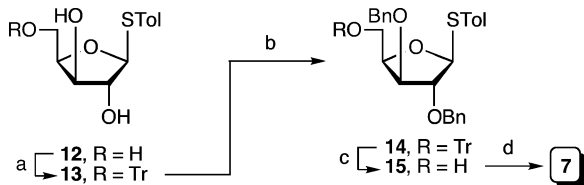

Chart 2

Scheme 1<sup>a</sup>

<sup>a</sup> (a) TrCl, pyridine, 0 °C → rt → 40 °C, 91%. (b) NaH, DMF, BnBr, 0 °C → rt, 81%. (c) cat. *p*-TsOH, CH<sub>3</sub>OH, CH<sub>2</sub>Cl<sub>2</sub>, rt, 83%. (d) TsCl, pyridine, 0 °C → rt, 87%.

**7** and **8**, while not known, were straightforwardly synthesized as described below.

The preparation of **7** (Scheme 1) began from thioglycoside triol **12**,<sup>30</sup> which was tritylated and benzylated under conventional conditions providing **14** in 74% yield over the two steps. The trityl group was then cleaved (*p*-TsOH/CH<sub>3</sub>OH) affording an 83% yield of alcohol **15**. Subsequent tosylation of **15** yielded **7** in 87% yield.

The synthesis of the enantiomeric thioglycoside, **8**, is illustrated in Scheme 2. In the first step, L-xylose<sup>31</sup> was converted to the corresponding furanose tetraacetate **16** in excellent yield

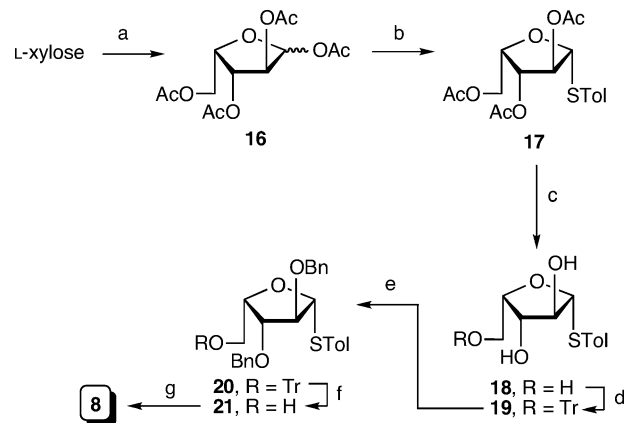
Scheme 2<sup>a</sup>

<sup>a</sup> (a) H<sub>3</sub>BO<sub>3</sub>, AcOH, Ac<sub>2</sub>O, 50 °C then Ac<sub>2</sub>O, pyridine, rt, 90%. (b) *p*-thiocresol, BF<sub>3</sub>·Et<sub>2</sub>O, CH<sub>2</sub>Cl<sub>2</sub>, -20 °C, 75%. (c) NaOCH<sub>3</sub>, CH<sub>3</sub>OH, CH<sub>2</sub>Cl<sub>2</sub>, rt, 84%. (d) TrCl, pyridine, 0 °C → rt → 40 °C, 89%. (e) NaH, DMF, BnBr, 0 °C → rt, 80%. (f) cat. *p*-TsOH, CH<sub>3</sub>OH, CH<sub>2</sub>Cl<sub>2</sub>, rt, 81%. (g) TsCl, pyridine, 0 °C → rt, 77%.

(90%) using the boric acid-mediated approach developed by Furneaux and co-workers.<sup>32</sup> Peracetate **16**, obtained as an ~2:1 anomeric mixture, was converted to thioglycoside **17** in 75% yield upon reaction with *p*-thiocresol and boron trifluoride etherate. Deacetylation of **17** with sodium methoxide in methanol provided, in 84% yield, triol **18**, the enantiomer of **12**. The synthesis of **8** from **18** was done via a sequence identical to that used for the preparation of **7** from **12**. Thus, tritylation of **18** yielded **19** (89% yield), which was then benzylated affording **20** in 80% yield. Cleavage of the trityl group in **20** provided alcohol **21**, which was then tosylated affording thioglycoside **8** in 62% yield over the two steps.

With sufficient quantities of building blocks **7**–**11** in hand, their coupling to provide disaccharides proceeded without significant problems. Shown in Scheme 3 is the synthesis of disaccharides containing the D-enantiomer of MTX (**1**–**3**).

The first step toward disaccharide **1** involved the reaction of thioglycoside **7** with mannopyranoside **9**, in the presence of *N*-iodosuccinimide and silver triflate. The product produced from this reaction, disaccharide **22**, was produced in 91% yield

(30) Tilekar, J. N.; Lowary, T. L. *Carbohydr. Res.* **2004**, *339*, 2895–2899.

(31) Ness, R. K. *Methods Carbohydr. Chem.* **1962**, *1*, 90–93.

(32) Furneaux, R. H.; Rendle, P. M.; Sims, I. M. *J. Chem. Soc., Perkin Trans. I* **2000**, 2011–2014.

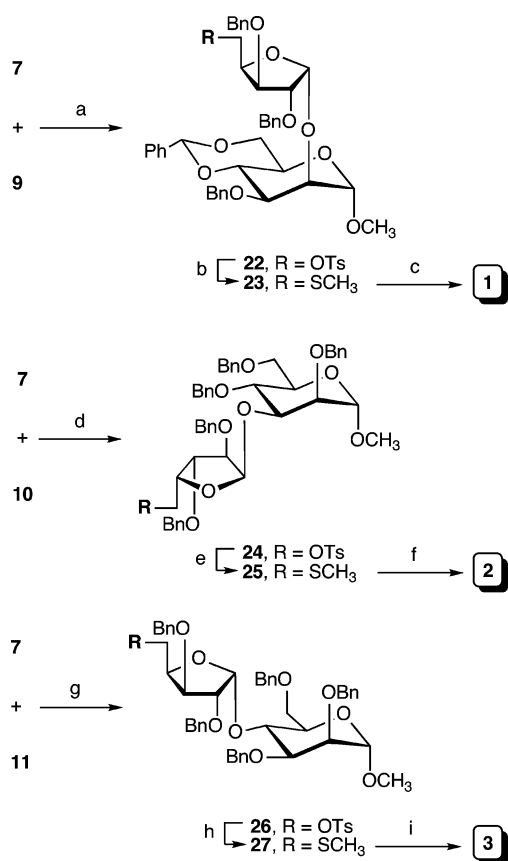
Scheme 3<sup>a</sup>

<sup>a</sup> (a) NIS, AgOTf, CH<sub>2</sub>Cl<sub>2</sub>, 0 °C → rt, 91%. (b) NaSCH<sub>3</sub>, 18-crown-6, CH<sub>3</sub>CN, reflux, 70%. (c) Na, NH<sub>3</sub>, THF, -78 °C, 61%. (d) NIS, AgOTf, CH<sub>2</sub>Cl<sub>2</sub>, 0 °C → rt, 73%. (e) NaSCH<sub>3</sub>, 18-crown-6, CH<sub>3</sub>CN, reflux, 72%. (f) Na, NH<sub>3</sub>, THF, -78 °C, 64%. (g) NIS, AgOTf, CH<sub>2</sub>Cl<sub>2</sub>, 0 °C → rt, 89%. (h) NaSCH<sub>3</sub>, 18-crown-6, CH<sub>3</sub>CN, reflux, 76%. (i) Na, NH<sub>3</sub>, THF, -78 °C, 89%.

as an inseparable 87:13  $\alpha$ : $\beta$  mixture of glycosides. The stereochemistry of the nascent glycosidic linkage could be readily established by NMR spectroscopy. In the major product, the coupling constant between H-1 and H-2 ( $^3J_{1,2}$ ) in the xylofuranose residue was 4.3 Hz as would be expected for a 1,2-cis furanoside.<sup>33</sup> In contrast, in the minor isomer, H-1 of the xylofuranose residue appeared as a singlet, consistent with the 1,2-trans furanoside stereochemistry.<sup>33</sup> Further support for the anomeric stereochemistry of the xylofuranose residue was obtained from the <sup>13</sup>C NMR spectrum of the product. For the major isomer, the anomeric carbon resonance appeared at 101.4 ppm, whereas in the minor isomer this resonance appeared at 106.1. Again, both of these data support the  $\alpha$ -stereochemistry of the major product.<sup>33</sup> These same two NMR parameters were used to establish the stereochemistry of the xylofuranosyl bond in all the disaccharides synthesized.

All glycosylations reported here were highly  $\alpha$ -selective providing, at worst, an 87:13  $\alpha$ : $\beta$  ratio of glycosides. Indeed, in some reactions, we were unable to isolate any of the  $\beta$ -glycoside product. This high selectivity for the 1,2-cis furanoside is in contrast to the synthesis of other 1,2-cis furanosides (e.g.,  $\beta$ -arabinofuranosides), which is often plagued with modest anomeric selectivity,<sup>34</sup> except under highly opti-

mized conditions.<sup>35,36</sup> We are unsure as to the origin of the high selectivities observed in glycosylations with **7** and **8** as compared to other furanoside glycosylating agents containing nonparticipating groups on O-2. It is plausible to speculate that the  $\alpha$ -xylofuranoside product is favored by the kinetic anomeric effect,<sup>37</sup> although in the absence of a detailed conformational study of the putative oxocarbenium ion involved in these reactions, this must remain only a hypothesis.

Because the separation of **22** from the corresponding  $\beta$ -isomer was not possible, the mixture was submitted to the next reaction, in which the methylthio group was introduced. This reaction was done by heating **22** together with sodium thiomethoxide and 18-Crown-6 in acetonitrile at reflux. The expected product, **23**, was produced in 70% yield, again contaminated with traces of its  $\beta$ -glycoside isomer. That the introduction of the methylthio group had occurred was obvious from the NMR spectra of **23**. In the <sup>1</sup>H NMR spectrum, the signals for the protons on C-5 of the xylofuranose residue were significantly upfield (2.85 and 2.70 ppm) of their position in the <sup>1</sup>H NMR spectrum of **22** (4.10 and 4.29 ppm). In addition, in the <sup>13</sup>C NMR spectrum of **23**, the resonance for the xylofuranose C-5 appeared at 34.1 ppm, consistent with its linkage to sulfur. Finally, as expected, a methyl group bound to sulfur was apparent in both the <sup>1</sup>H and <sup>13</sup>C spectra (resonances as 2.16 and 16.5 ppm, respectively). Similar features were observed in the NMR spectra for all products of these substitution reactions.

With the methylthio group in place, the final step in the synthesis of **1** was the cleavage of the benzyl ethers and the benzylidene acetal, which was done by dissolving metal reduction. Thus, treatment of a solution of **23** in THF at -78 °C with sodium and ammonia cleaved all protecting groups. Following purification, disaccharide **1** was isolated in 61% yield.

The synthesis of **2** followed a similar sequence to that used for the preparation of **1**. Glycosylation of **10** with **7** promoted by *N*-iodosuccinimide and silver triflate gave disaccharide **24**, as an inseparable mixture with the  $\beta$ -glycoside and small amounts of hydrolyzed **7**. The mixture was then subjected to the thiolate substitution reaction, which gave, following chromatography, **25** as a pure compound in 53% overall yield from **10**. Removal of the benzyl ethers upon treatment of **25** with sodium and liquid ammonia in THF proceeded uneventfully, yielding **2** in 64% yield.

The same series of transformations was used to convert **11** and **7** into disaccharide **3**. The coupling of **11** and **7** under standard conditions gave the expected disaccharide **26**, which, following chromatography, was also contaminated with traces of hydrolyzed **7**. This partially pure product was then reacted with sodium thiomethoxide to give **27** in 66% yield from **11**. Disaccharide **3** was obtained in 89% yield upon treatment of **27** with sodium in liquid ammonia.

The synthesis of disaccharides containing an L-MTX residue (**4–6**) is shown in Scheme 4. The oligosaccharides were synthesized via the same routes used for the preparation of **1–3**, by replacing donor **7** with **8**. The protected disaccharides were thus obtained in yields of 71–82% upon reaction of **8** with one

(33) Cyr, N.; Perlin, A. S. *Can. J. Chem.* **1979**, *57*, 2504–2511.

(34) Yin, H.; Lowary, T. L. *Tetrahedron Lett.* **2001**, *42*, 5829–5832.

(35) Yin, H.; D'Souza, F. W.; Lowary, T. L. *J. Org. Chem.* **2002**, *67*, 892–903.

(36) Lee, Y. J.; Lee, K.; Jung, E. H.; Jeon, H. B.; Kim, K. S. *Org. Lett.* **2005**, *7*, 3263–3266.

(37) Juaristi, E.; Cuevas, G. *The Anomeric Effect*; CRC Press: Boca Raton, FL, 1995; pp 182–194.

**Table 1.** Comparison of NMR Chemical Shift Data for the 5-Deoxy-5-methylthio-xylofuranose Residue in **1–6** with Those Found in LAM from *M. tuberculosis* H37Ra<sup>a</sup>

compound	<sup>1</sup> H δ (ppm)							<sup>13</sup> C δ (ppm)					
	H-1	H-2	H-3	H-4	H-5	H-5'	SCH <sub>3</sub>	C-1	C-2	C-3	C-4	C-5	SCH <sub>3</sub>
<b>1</b>	5.30	4.21	4.27	4.40	2.69	2.80	2.18	105.8	80.4	78.5	80.6	35.6	17.9
<b>2</b>	5.36	4.20	4.29	4.43	2.69	2.81	2.17	105.4	80.4	78.5	80.6	35.6	17.8
<b>3</b>	<b>5.41</b>	<b>4.21</b>	<b>4.26</b>	<b>4.38</b>	<b>2.68</b>	<b>2.80</b>	<b>2.18</b>	<b>105.3</b>	<b>79.4</b>	<b>78.4</b>	<b>80.6</b>	<b>35.8</b>	<b>17.8</b>
<b>4</b>	5.25	4.19	4.30	4.47	2.68	2.79	2.16	103.0	80.0	78.3	80.4	35.6	17.7
<b>5</b>	5.27	4.20	4.31	4.47	2.68	2.80	2.16	103.4	80.2	78.4	80.2	35.7	17.7
<b>6</b>	5.21	4.20	4.28	4.47	2.68	2.80	2.16	104.6	79.6	78.2	80.3	35.8	17.8
experiment <sup>b</sup>	<b>5.40</b>	<b>4.21</b>	<b>4.26</b>	<b>4.38</b>	<b>2.68</b>	<b>2.80</b>	<b>2.21</b>	<b>105.2</b>	<b>79.4</b>	<b>78.3</b>	<b>80.5</b>	<b>35.8</b>	<b>17.4</b>

<sup>a</sup> NMR spectra were recorded in D<sub>2</sub>O, and chemical shifts are referenced to 3-(trimethylsilyl)-propionic acid, sodium salt at 0.0 ppm. <sup>b</sup> Taken from ref 25.

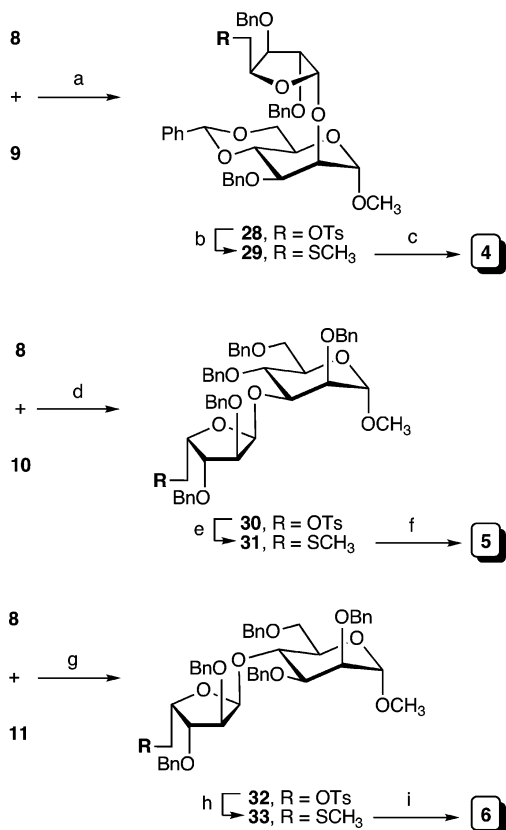
**Scheme 4**<sup>a</sup>

<sup>a</sup> (a) NIS, AgOTf, CH<sub>2</sub>Cl<sub>2</sub>, 0 °C → rt, 73%. (b) NaSCH<sub>3</sub>, 18-crown-6, CH<sub>3</sub>CN, reflux, 71%. (c) Na, NH<sub>3</sub>, THF, -78 °C, 63%. (d) NIS, AgOTf, CH<sub>2</sub>Cl<sub>2</sub>, 0 °C → rt, 82%. (e) NaSCH<sub>3</sub>, 18-crown-6, CH<sub>3</sub>CN, reflux, 70%. (f) Na, NH<sub>3</sub>, THF, -78 °C, 65%. (g) NIS, AgOTf, CH<sub>2</sub>Cl<sub>2</sub>, 0 °C → rt, 71%. (h) NaSCH<sub>3</sub>, 18-crown-6, CH<sub>3</sub>CN, reflux, 77%. (i) Na, NH<sub>3</sub>, THF, -78 °C, 67%.

of acceptors **9–11**. The resulting products **28**, **30**, and **32** were then converted to the methylthio analogues **29**, **31**, and **33** in 70–77% yield and subsequently deprotected by dissolving metal reduction, yielding **4–6** in 63–67% yield.

**Determination of Absolute Stereochemistry and Linkage Position of MTX Residue.** Having synthesized oligosaccharides **1–6**, we next carried out a series of two-dimensional NMR experiments (COSY and HMQC) on each to fully assign all <sup>1</sup>H and <sup>13</sup>C resonances for comparison with the data obtained for the MTX residue present in mycobacterial LAM. The chemical shift data of the MTX residue in **1–6** are provided in Table 1, together with the data previously reported for this substituent in *M. tuberculosis* H37Ra LAM.<sup>25</sup>

Perusing these data it is possible to quickly determine that the MTX residue in the polysaccharide is not of the L-configuration. First, the anomeric hydrogen for this residue in **4–6** resonates between 5.21 and 5.27 ppm, whereas in the polysaccharide the chemical shift for this hydrogen resonance was reported to be 5.40 ppm, a difference of more than 0.13 ppm. Similarly, the chemical shift of the anomeric carbon residue in **4–6** resonates between 103.0 and 104.6 ppm, which is 0.6–2.2 ppm lower than that reported for the MTX substituent in the polysaccharide. In contrast, the data for **1–3**, which contains an MTX residue with the D-configuration, matches the polysaccharide data better. The MTX anomeric hydrogen resonances in **1–3** are found between 5.30 and 5.41 ppm, differing 0.01–0.1 ppm from the polysaccharide. The chemical shift data for the anomeric carbon compare even better, with these ranging from 105.3 to 105.8 ppm in **1–3** vs 105.2 in the polysaccharide.

Having established the absolute stereochemistry of the MTX substituent as D, we turned our attention to the position on the mannose residue to which it was linked. Looking first at the <sup>1</sup>H NMR data, the best fit to the polysaccharide is **3**, the isomer in which the linkage is α-(1→4). In particular, for the anomeric hydrogen resonance, the chemical shift difference with the polysaccharide is 0.1 ppm (**1**), 0.04 ppm (**2**), and 0.01 ppm (**3**). The same conclusion can be drawn from the <sup>13</sup>C NMR data. The chemical shift of the anomeric carbon in **3** differed from that reported for the polysaccharide by only 0.1 ppm, as compared to 0.6 and 0.2 ppm for **1** and **2**, respectively. However most telling were the differences in the chemical shifts of the MTX C-2 resonances. In **3**, the value (79.4 ppm) matched that of the polysaccharide exactly, while in **1** and **2**, this resonance was a full ppm more downfield, resonating at 80.4 ppm. Overall, none of the chemical shift data for the polysaccharide differed from that of **3** by more than 0.03 ppm for the <sup>1</sup>H data and 0.4 ppm for the <sup>13</sup>C NMR data. The largest differences were seen in the data for the methylthio group (0.03 and 0.4, respectively). When these data are taken out of the comparison, the differences between **3** and the polysaccharide differed by no more than 0.01 ppm for the <sup>1</sup>H data and no more than 0.1 for the <sup>13</sup>C data. We are unsure as to why the data for the methylthio group in **3** agrees comparatively poorly with that reported for the polysaccharide, but we note that similarly poor agreement was seen in the study establishing the xylo stereochemistry of this substituent.<sup>27</sup> Based on our analysis of these data, we propose that the MTX substituent in *M. tuberculosis* has the D-configuration and is linked α-(1→4) to a mannopyranose residue present in the capping domains.

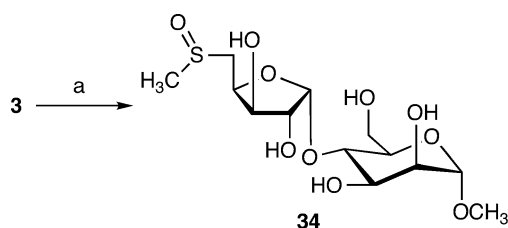
Scheme 5<sup>a</sup>

<sup>a</sup> (a) 30% aqueous H<sub>2</sub>O<sub>2</sub>, rt, 81%.

**Table 2.** Comparison of NMR Chemical Shift Data for the Diastereomeric 5-Deoxy-5-methylsulfoxy-xylofuranose Residues in **34** with Those Found in LAM from *M. tuberculosis* H37Ra<sup>a</sup>

resonance	<b>34a</b>	MSP-1 <sup>b</sup>	<b>34b</b>	MSP-2 <sup>b</sup>
H-1	5.47	5.45	5.46	5.44
H-2	4.23	4.22	4.20	4.20
H-3	4.34	4.34	4.34	4.34
H-4	4.62	4.61	4.65	4.65
H-5	3.12	3.12	3.29	3.28
H-5'	3.12	3.12	3.09	3.08
S(O)CH <sub>3</sub>	2.81	2.84	2.80	2.83
<hr/>				
C-1	105.6	105.4	105.6	105.4
C-2	79.1	79.3	79.4	79.4
C-3	78.6	78.5	78.6	78.5
C-4	75.7	75.6	76.4	76.5
C-5	57.2	57.1	55.7	55.6
S(O)CH <sub>3</sub>	40.6	40.2	40.2	39.9

<sup>a</sup> NMR spectra were recorded in D<sub>2</sub>O, and chemical shifts are referenced to 3-(trimethylsilyl)-propionic acid, sodium salt at 0.0 ppm. <sup>b</sup> Taken from ref 25.

Additional evidence for this assignment was obtained by oxidizing **3** into the corresponding diastereomeric mixture of sulfoxides upon treatment with hydrogen peroxide. As shown in Scheme 5, the product was obtained in 81% yield. Comparison of the NMR data for **34** with that of the MSX residue in the polysaccharide (Table 2) showed excellent agreement, thus further bolstering support for the proposed MTX- $\alpha$ -(1 $\rightarrow$ 4)-mannopyranose linkage. The <sup>1</sup>H NMR data for the furanose residue in **34** differed by no more than 0.03 ppm from the polysaccharide, while for the <sup>13</sup>C NMR data the chemical shifts were all within 0.4 ppm of those reported. As was the case for **3**, the worst agreement was seen for the resonance associated with the methylsulfoxyl group.

As mentioned previously, in addition to being present in *M. tuberculosis* LAM, the MTX residue has also been found in LAM from *M. kansasii* (KanLAM).<sup>28</sup> However, it was demonstrated that in KanLAM the MTX residue is not attached via the capping motifs of the polysaccharide, but rather to the mannan core. To determine if the linkage position and absolute stereochemistry of the *M. kansasii* MTX moiety is the same as that in *M. tuberculosis* LAM, the NMR data for **3** were compared to those obtained for KanLAM (Table 3).<sup>38</sup> As can be seen from the table, there is good agreement between the data for **3** and those for the polysaccharide, and thus we conclude that, like in *M. tuberculosis* LAM, the MTX residue in KanLAM is also of the D-configuration and is linked  $\alpha$ -(1 $\rightarrow$ 4) to a mannopyranose residue.

(38) In the work reported in ref 28, the NMR spectroscopy of the polysaccharide was done using DMSO-*d*<sub>6</sub> as the solvent. Therefore, we rerecorded the NMR spectrum for **3** in DMSO-*d*<sub>6</sub>.

**Table 3.** Comparison of NMR Chemical Shift Data for the 5-Deoxy-5-methylthio-xylofuranose Residue of **3** with Those Found in LAM from *M. kansasii* (KanLAM)<sup>a</sup>

resonance	<b>3</b>	KanLAM <sup>b</sup>
H-1	5.24	5.23
H-2	3.90	3.90
H-3	3.98	3.99
H-4	4.18	4.18
H-5	2.70	2.70
H-5'	2.53	2.53
SCH <sub>3</sub>	2.12	2.10
<hr/>		
C-1	104.1	103.9
C-2	78.4	78.0
C-3	76.6	76.3
C-4	80.1	79.7
C-5	34.5	34.4
SCH <sub>3</sub>	16.8	16.5

<sup>a</sup> NMR spectra were recorded in DMSO-*d*<sub>6</sub>, and chemical shifts are referenced to the methyl group of the solvent at 2.52 ppm (<sup>1</sup>H) or 40.98 ppm (<sup>13</sup>C). <sup>b</sup> Taken from ref 28.

Chart 3

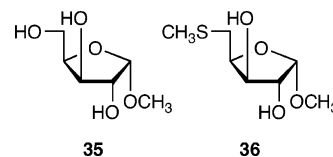

**Conformation of the MTX Residue.** In previous studies<sup>39,40</sup> we completed a conformational analysis of the methyl  $\alpha$ -D-xylofuranoside (**35**, Chart 3), which showed that it differs from many other furanosides in that it is relatively rigid. Using NMR spectroscopy and computational chemistry we established that the favored ring conformer is an envelope in which C-1 is displaced below the plane (E<sub>1</sub>), which is very similar to the conformation present in the crystal structure of **35**.<sup>41</sup> When analyzing the NMR data for **3** and **34** it was immediately apparent that the coupling constants of the MTX residue were significantly different than those in **35** thus indicating differences in conformation.

To obtain a more quantitative picture of these conformational differences, we carried out PSUEROT<sup>42–44</sup> calculations on the MTX rings in **3**, the diastereomers of **34**, and the corresponding methyl glycoside **36** (Chart 3, prepared as described in the Supporting Information). The conformation of **36** was evaluated to determine what, if any, role the aglycone plays in the conformational equilibrium of the furanose ring. The PSEUROT approach<sup>43</sup> is a commonly used method for assessing the solution conformation of five-membered rings and involves the measurement of the three bond <sup>1</sup>H–<sup>1</sup>H coupling constants (<sup>3</sup>J<sub>HH</sub>) of the ring hydrogens and subsequent analysis of these data. The program assumes a model in which two conformers are present, one in the northern hemisphere of the pseudorotational wheel<sup>45</sup> (Figure 2), the other in the southern hemisphere. These

(39) Houseknecht, J. B.; Lowary, T. L.; Hadad, C. M. *J. Phys. Chem. A* **2003**, *107*, 372–378.

(40) Houseknecht, J. B.; Lowary, T. L.; Hadad, C. M. *J. Phys. Chem. A* **2003**, *107*, 5763–5777.

(41) Evdokimov, A.; Gilboa, A. J.; Koetzle, T. F.; Klooster, W. T.; Schulz, A. J.; Mason, S. A.; Albinati, A.; Frolow, F. *Acta Crystallogr. B* **2001**, *57*, 213–220.

(42) PSEUROT 6.2 (1993), PSEUROT 6.3 (1999): van Wijk, J.; Haasnoot, C. A. G.; de Leeuw, F. A. A. M.; Huckriede, B. D.; Westra Hoekzema, A.; Altona, C. Leiden Institute of Chemistry, Leiden University.

(43) de Leeuw, F. A. A. M.; Altona, C. *J. Comput. Chem.* **1983**, *4*, 428–437.

(44) Altona, C. *Recl. Trav. Chim. Pays-Bas* **1982**, *101*, 413–433.

(45) Altona, C.; Sundaralingam, M. *J. Am. Chem. Soc.* **1972**, *94*, 8205–8212.

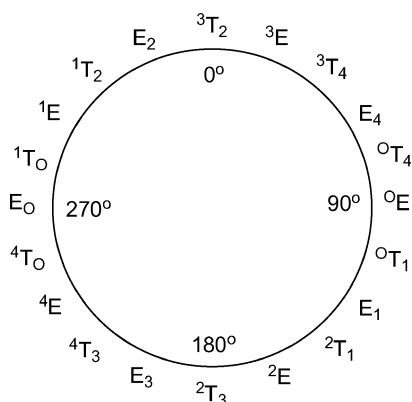

Figure 2. Pseudorotational wheel for a D-aldofuranose ring.

Table 4. Results of PSUEROT Calculations for **3** and **34–36**<sup>a,b</sup>

	compound				
	<b>3</b>	<b>34a</b>	<b>34b</b>	<b>35</b> <sup>c</sup>	<b>36</b>
$P_N$	14	20	14	324	13
%N	50	43	45	8	48
$P_S$	137	135	137	124	131
%S	50	57	55	92	52
RMS <sup>d</sup>	0.0	0.0	0.0	0.0	0.0

<sup>a</sup> Calculated using a constant  $\Phi_m$  (Altona-Sundaralingam puckering amplitude) = 40° for all compounds. <sup>b</sup>  $P$  = Altona-Sundaralingam pseudorotational phase angle. <sup>c</sup> Taken from ref 40. <sup>d</sup> In Hz.

conformers, termed North (N) or South (S), equilibrate via pseudorotation.<sup>46,47</sup>

The results of these PSEUROT analyses are provided in Table 4, where they are compared to the populations in the parent structure **35**. It is clear that the replacement of the C-5 hydroxyl group with the 5-thiomethyl substituent (**3**, **36**) or with the corresponding sulfoxide (**34**) does alter the conformational equilibrium of the furanose ring. In comparison to **35**, the C-5 modified analogues are more flexible, all adopting roughly equimolar mixtures of two conformers, as opposed to an equilibrium in which a single conformer predominates. In addition, this modification alters the conformers present in the equilibrium mixture. Although the identity of the S conformer remains approximately the same, shifting slightly south from E<sub>1</sub> toward <sup>2</sup>T<sub>1</sub> ( $P = 124^\circ \rightarrow P = 131^\circ\text{--}137^\circ$ ), the change in the N conformer is more dramatic, moving from approximately <sup>1</sup>E ( $P = 324^\circ$ ) to <sup>3</sup>E ( $P = 13^\circ\text{--}20^\circ$ ). The origin of this conformational shift is unclear; however, the observation that **3** and **36** have essentially identical conformer distributions rules out the aglycone as a cause of these changes. Beyond that, it is plausible to speculate that the conformational shift is driven by eclipsing interactions between OH-3 and the substituent attached to C-5. In the parent structure **35**, in which the C-5 substituent is OH, the predominant ring conformer is E<sub>1</sub>. The OH-3 and C-5 are nearly perfectly eclipsed in this conformer, but the energetic penalty for this negative interaction is apparently compensated for by the pseudoaxial orientation of the OCH<sub>3</sub> group, which maximizes the anomeric effect. In the minor conformer of **35** (<sup>1</sup>E) these groups are also eclipsed. It could be expected that as the size of the C-5 substituent is increased (e.g., changing OH to SCH<sub>3</sub> or S(O)CH<sub>3</sub>) these eclipsing

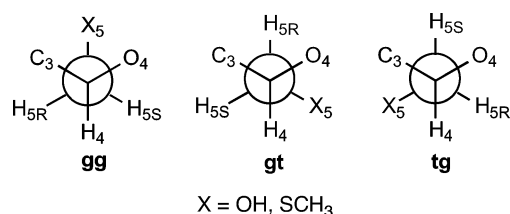

Figure 3. Definition of gg, gt, and tg rotamers about the C-4–C-5 bond.

Table 5. C-4–C-5 Rotamer Populations for **3**, **35**, and **36**<sup>a</sup>

	compound		
	<b>3</b>	<b>36</b>	<b>35</b>
$X_{gg}(\%)$	14	12	40
$X_{gt}(\%)$	63	57	46
$X_{tg}(\%)$	24	30	14

<sup>a</sup> See Figure 3 for rotamer definitions.

interactions become more important, in turn favoring conformations (e.g., <sup>3</sup>E) in which C-5 and OH-3 are staggered.

**Conformation about the C-4–C-5 Bond in the MTX Residue.** In addition to influencing the conformation of the five-membered ring, the replacement of the C-5 hydroxyl group with SCH<sub>3</sub> is expected to alter rotamer populations about the C-4–C-5 bond (Figure 3). Thus, through analysis of <sup>3</sup>J<sub>4,5S</sub> and <sup>3</sup>J<sub>4,5R</sub> measured from the <sup>1</sup>H NMR spectrum of **3** and **36** these rotamer populations have been determined. Analysis of the coupling constant data was done as outlined in the Experimental Section.

The C-4–C-5 rotamer populations for **3**, **35**, and **36** are presented in Table 5. In the parent structure, **35**, the two major rotamers are gg and gt, conformers that are stabilized by a gauche interaction with the ring oxygen.<sup>48</sup> These two rotamers are present in roughly equal amounts and predominate over the tg conformer, in which the oxygen is trans to the ring oxygen. In the methylthio substituted analogues **3** and **36** this distribution is shifted. In particular, the population of the tg and gt conformers increase at the expense of the gg rotamer. This change is presumably driven by unfavorable steric interactions between the ring and the comparatively bulky methylthio substituent when adopting the gg conformation. Similarly, the preference for the gt over tg rotamer is likely due to unfavorable steric clashing between the methylthio group and the C-3 hydroxyl group. Previous conformational studies on 4'-thio-nucleoside derivatives showed a similar increase in tg rotamer when compared to their 4'-oxo counterparts.<sup>49</sup> This conformational shift was ascribed, in part, to the preference for 1-alkoxy-2-alkylthio ethane fragments to adopt trans rather than gauche conformations<sup>50,51</sup> and the same stereoelectronic effect may contribute to the differences between rotamer populations in **3** and **36** compared to **35**.

**Effect of **3** and **34** on TNF- $\alpha$  and IL-12p70 Production.** The distribution of the MTX residue in a number of different mycobacterial strains suggests that this motif has an important biological function. However, to date, no role for this monosaccharide has been identified. Given its location in the capping motif in LAM from *M. tuberculosis* we hypothesized that it

(48) Wolfe, S. *Acc. Chem. Res.* **1972**, *5*, 102–111.

(49) Crmugelj, M.; Dukhan, D.; Barascut, J.-L.; Imbach, J.-L.; Plavec, J. *J. Chem. Soc., Perkin Trans. 2* **2000**, 255–262.

(50) Yokoyama, Y.; Ohashi, Y. *Bull. Chem. Soc. Jpn.* **1998**, *71*, 1565–1571.

(51) Harada, T.; Yoshida, H.; Ohno, K.; Matsuura, H. *Chem. Phys. Lett.* **2002**, *362*, 453–460.

(46) Kilpatrick, J. E.; Pitzer, K. S.; Spitzer, R. *J. Am. Chem. Soc.* **1947**, *69*, 2483–2488.

(47) Pitzer, K. S.; Donath, W. E. *J. Am. Chem. Soc.* **1959**, *81*, 3213–3218.

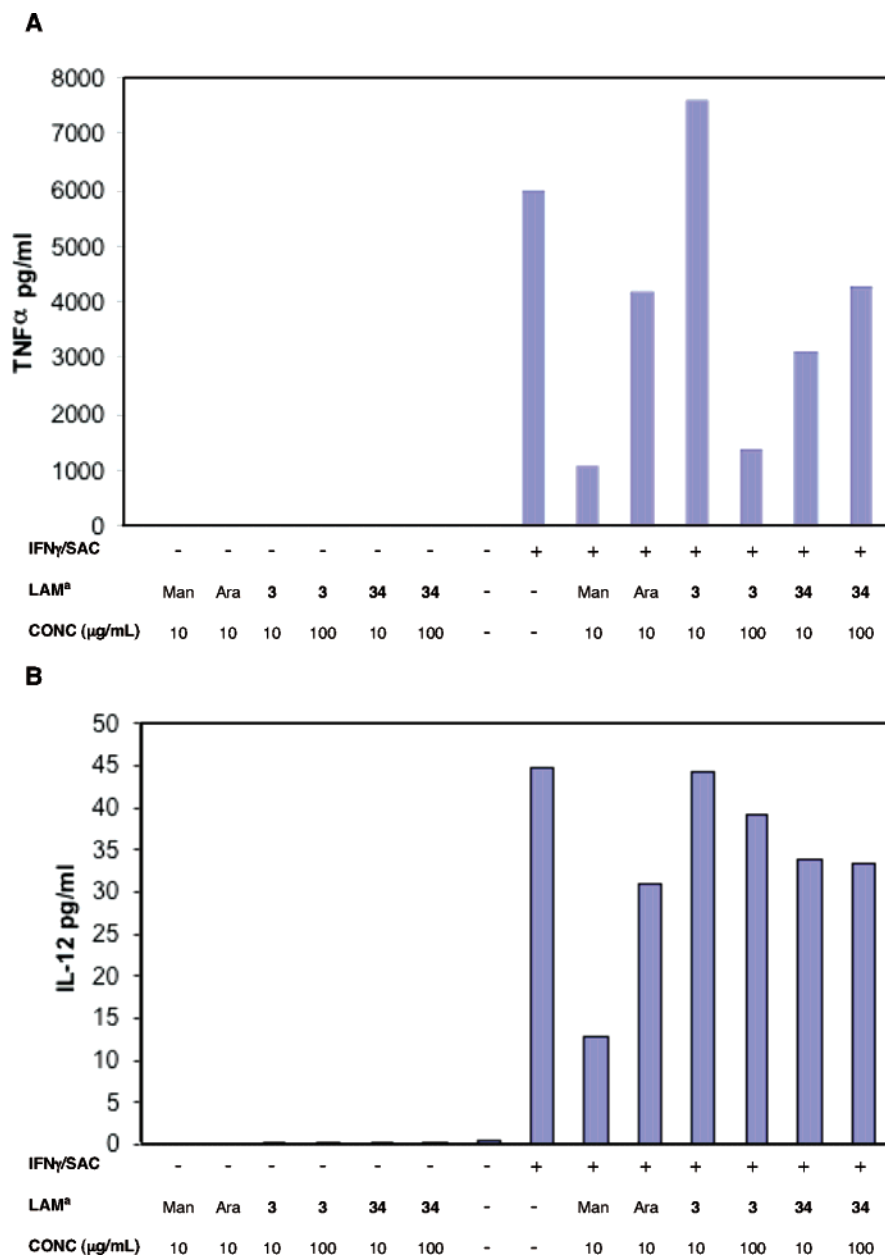

**Figure 4.** (A) Average TNF- $\alpha$  production by THP-1 cells in response to IFN $\gamma$ /SAC (8 h), following preincubation with synthetic/natural LAM derivatives (24 h), ( $n = 2$ ). (B) Average IL-12p70 production by THP-1 cells in response to IFN $\gamma$ /SAC (8 h), following preincubation with synthetic/natural LAM derivatives (24 h), ( $n = 3$ ). <sup>a</sup>Man = ManLAM; Ara = AraLAM.

may function as an immunomodulatory species and we thus evaluated the ability of **3** and **34** to induce or inhibit the production of the TNF- $\alpha$  and IL-12p70 using a human monocytic cell line (THP-1). The results of these studies are summarized in Figure 4.

As expected, treatment of THP-1 cells with a preparation of Interferon- $\gamma$  and *Staphylococcus aureus* Cowan strain (SAC/IFN- $\gamma$ ) led to a strong production of both TNF- $\alpha$  (Figure 4a) and IL-12p70 (Figure 4b). Neither **3** nor **34**, when tested at concentrations of 10 or 100  $\mu$ g/mL, significantly induced the production of these two cytokines. As a comparison, both ManLAM and AraLAM were tested at 10  $\mu$ g/mL and in line with previous investigations<sup>10</sup> also did not lead to TNF- $\alpha$  or IL-12p70 induction. When **3** and **34** were tested as inhibitors of the cytokine response induced by SAC/IFN- $\gamma$ , modest levels of inhibition were observed. For TNF- $\alpha$  (Figure 4a), **3** at a

concentration of 100  $\mu$ g/mL led to a level of inhibition comparable with ManLAM at 10  $\mu$ g/mL, whereas **34** (at 10  $\mu$ g/mL) was less effective and comparable to AraLAM at 10  $\mu$ g/mL. These compounds were poorer inhibitors of IL-12p70, with both **3** and **34** exerting only a very modest effect at either 10 or 100  $\mu$ g/mL.

Because of the significant molecular weight differences among **3**, **34**, and the two polysaccharides, we also carried out assays in which the concentration of these compounds was kept constant (see Figure S1 in Supporting Information). A concentration of 5  $\mu$ M was used in these assays, which is the approximate molarity of a 10  $\mu$ g/mL solution of ManLAM (mw  $\sim$ 17 400). For the TNF- $\alpha$  assays, the trends were the same as those shown in Figure 4a, i.e., a 5  $\mu$ M concentration of **3** inhibited TNF- $\alpha$  production to a similar degree as a 5  $\mu$ M concentration of ManLAM. In addition, **34** was a weaker



inhibitor than **3**. The results with IL-12p70 (Figure S2) were also similar to those shown in Figure 4b; neither **3** or **34** at 5  $\mu$ M inhibited the production of the cytokine to the degree of the same concentration of ManLAM. For IL-12p70, **3** had a similar activity as that of AraLAM, whereas **34** was less active.

Finally, as controls we tested compounds **1**, **2**, **6**, and **36** at 5  $\mu$ M in both assays. In the case of TNF- $\alpha$ , none of these compounds inhibited cytokine induction (Figure S1). Indeed, each appeared to induce production of TNF- $\alpha$  to varying degrees. For IL-12p70, all four of these compounds also inhibited induction, but to a degree intermediate between **3** and **34**. These results suggest that the inhibition of TNF- $\alpha$  by **3** and **34** is specific to the structures of the molecules, while for IL-12p70 the effect is nonspecific.

## Conclusions

In summary, through the combined use of chemical synthesis and NMR spectroscopy, we have established that the 5-deoxy-5-methylthio-xylofuranose (MTX) and 5-deoxy-5-methylsulfoxy-xylofuranose (MSX) residues present in the LAM of *M. tuberculosis* and *M. kansasii* are of the D-configuration and are linked  $\alpha$ -(1 $\rightarrow$ 4) to a mannopyranose residue in the glycan. Conformational analysis of these residues indicated differences in both ring conformation and rotamer populations about the C-4–C-5 bond, as compared to the parent compound, methyl  $\alpha$ -D-xylofuranoside (**35**). Two of the synthesized disaccharides, **3** and **34**, when tested in assays of cytokine induction did not lead to production of TNF- $\alpha$  or IL-12p70; however, both showed modest inhibitory properties when these cytokines were induced using SAC/IFN- $\gamma$ . These latter observations suggest that this motif may play a role in the immune response arising from mycobacterial infection.

## Experimental Section

**General Methods.** Reactions were carried out in oven-dried glassware. Reaction solvents were distilled from appropriate drying agents before use. Unless stated otherwise, all reactions were carried out with stirring at room temperature under a positive pressure of argon and were monitored by TLC on silica gel 60 F<sub>254</sub> (0.25 mm, E. Merck). Spots were detected under UV light or by charring with acidified *p*-anisaldehyde solution in ethanol. In the processing of reaction mixtures, solutions of organic solvents were washed with equal amounts of aqueous solutions. Organic solutions were concentrated under a vacuum at <40 °C. All column chromatography was performed on silica gel (40–60  $\mu$ M) or Iatrobeads, which refers to a beaded silica gel 6RS-8060, manufactured by Iatron Laboratories (Tokyo). In all cases the ratio between adsorbent and crude product ranged from 100 to 50:1 (w/w). Optical rotations were measured at 22  $\pm$  2 °C and in units of degrees mL/g dm. <sup>1</sup>H NMR spectra were recorded at 400 or 500 MHz, and chemical shifts were referenced to either tetramethylsilane (0.0, CDCl<sub>3</sub>), CD<sub>3</sub>OH (4.78, CD<sub>3</sub>OD) or 3-(trimethylsilyl)-propionic acid, sodium salt (0.0, D<sub>2</sub>O). <sup>13</sup>C NMR spectra were recorded at 100 or 125 MHz, and <sup>13</sup>C chemical shifts were referenced to internal CDCl<sub>3</sub> (77.23, CDCl<sub>3</sub>), CD<sub>3</sub>OD (48.9, CD<sub>3</sub>OD) or 3-(trimethylsilyl)-propionic acid, sodium salt (0.0, D<sub>2</sub>O). <sup>1</sup>H data are reported as though they were first order. Electrospray mass spectra were recorded on samples suspended in mixtures of THF with CH<sub>3</sub>OH and added NaCl.

**Methyl 2-O-(5-Deoxy-5-methylthio- $\alpha$ -D-xylofuranosyl)- $\alpha$ -D-mannopyranoside (**1**).** Disaccharide **23** (21 mg, 0.03 mmol) was dissolved in THF (5 mL), the solution was cooled to –78 °C, and then NH<sub>3</sub> (20 mL) was condensed into the flask using a dry ice trap. Sodium metal (80 mg) was added in three portions until a deep blue color persisted. The solution was stirred for 1.5 h at –78 °C, and then CH<sub>3</sub>OH (2 mL)

was added. The flask was warmed to rt and left open to the atmosphere overnight to allow the NH<sub>3</sub> to evaporate. The remaining solution was concentrated, and the resulting residue was dissolved in a minimum amount of CH<sub>3</sub>OH before being neutralized with glacial HOAc. The solution was again concentrated, and the semisolid residue was purified by column chromatography on Iatrobeads (85:15, CH<sub>2</sub>Cl<sub>2</sub>/CH<sub>3</sub>OH) to afford **1** (6 mg, 61%) as a foam (data for major isomer). *R*<sub>f</sub> 0.24 (85:15, CH<sub>2</sub>Cl<sub>2</sub>/CH<sub>3</sub>OH); [ $\alpha$ ]<sub>D</sub> +75.2 (*c* 0.4, CH<sub>3</sub>OH); <sup>1</sup>H NMR (500 MHz, D<sub>2</sub>O,  $\delta$ <sub>H</sub>) 5.30 (d, 1 H, *J* = 4.5 Hz, H-1'), 4.93 (d, 1 H, *J* = 1.7 Hz, H-1), 4.40 (ddd, 1 H, *J* = 4.8, 5.0, 8.6 Hz, H-4'), 4.27 (dd, 1 H, *J* = 4.2, 4.5 Hz, H-3'), 4.21 (dd, 1 H, *J* = 4.5, 4.5 Hz, H-2'), 3.99 (dd, 1 H, *J* = 1.7, 3.4 Hz, H-2), 3.89 (dd, 1 H, *J* = 1.9, 12.3 Hz, H-6), 3.85 (dd, 1 H, *J* = 3.4, 9.7 Hz, H-3), 3.80 (dd, 1 H, *J* = 5.6, 12.3 Hz, H-6), 3.71 (dd, 1 H, *J* = 9.7, 9.7 Hz, H-4), 3.63–3.60 (m, 1 H, H-5), 3.42 (s, 3 H, OCH<sub>3</sub>), 2.80 (dd, 1 H, *J* = 5.0, 13.8 Hz, H-5'), 2.69 (dd, 1 H, *J* = 8.6, 13.8 Hz, H-5'), 2.18 (s, 3 H, SCH<sub>3</sub>); <sup>13</sup>C NMR (125 MHz, D<sub>2</sub>O,  $\delta$ <sub>C</sub>) 105.8 (C-1'), 103.0 (C-1), 80.8 (C-2), 80.6 (C-4'), 80.4 (C-2'), 78.5 (C-3'), 75.3 (C-5), 73.2 (C-3), 69.6 (C-4), 63.5 (C-6), 57.8 (OCH<sub>3</sub>), 35.6 (C-5'), 17.9 (SCH<sub>3</sub>). HRMS (ESI) calcd for (M + Na) C<sub>13</sub>H<sub>24</sub>O<sub>9</sub>S 379.1033, found 379.1032.

**Methyl 3-O-(5-Deoxy-5-methylthio- $\alpha$ -D-xylofuranosyl)- $\alpha$ -D-mannopyranoside (**2**).** Prepared from **25** (24 mg, 0.03 mmol), liquid NH<sub>3</sub> (20 mL), and sodium metal (80 mg) in THF (5 mL) as described for **1**, to afford **2** (7 mg, 64%) as a foam. *R*<sub>f</sub> 0.4 (85:15, CH<sub>2</sub>Cl<sub>2</sub>/CH<sub>3</sub>OH); [ $\alpha$ ]<sub>D</sub> +106.6 (*c* 0.5, CH<sub>3</sub>OH); <sup>1</sup>H NMR (500 MHz, D<sub>2</sub>O,  $\delta$ <sub>H</sub>) 5.36 (d, 1 H, *J* = 4.5 Hz, H-1'), 4.76 (s, 1 H, H-1), 4.43 (ddd, 1 H, *J* = 5.3, 5.0, 8.4 Hz, H-4'), 4.29 (dd, 1 H, *J* = 4.0, 5.3 Hz, H-3'), 4.20 (dd, 1 H, *J* = 4.5, 4.0 Hz, H-2'), 4.14–4.11 (m, 1 H, H-2), 3.92–3.86 (m, 2 H, H-3, H-6), 3.82–3.75 (m, 2 H, H-4, H-6), 3.69–3.65 (m, 1 H, H-5), 3.42 (s, 3 H, OCH<sub>3</sub>), 2.81 (dd, 1 H, *J* = 5.0, 13.8 Hz, H-5'), 2.69 (dd, 1 H, *J* = 8.4, 13.8 Hz, H-5'), 2.17 (s, 3 H, SCH<sub>3</sub>); <sup>13</sup>C NMR (125 MHz, D<sub>2</sub>O,  $\delta$ <sub>C</sub>) 105.4 (C-1'), 103.5 (C-1), 81.6 (C-2), 80.6 (C-4'), 80.4 (C-2'), 78.5 (C-3'), 75.4 (C-5), 72.9 (C-3), 68.6 (C-4), 63.7 (C-6), 57.7 (OCH<sub>3</sub>), 35.6 (C-5'), 17.8 (SCH<sub>3</sub>). HRMS (ESI) calcd for (M + Na) C<sub>13</sub>H<sub>24</sub>O<sub>9</sub>S 379.1033, found 379.1032.

**Methyl 4-O-(5-Deoxy-5-methylthio- $\alpha$ -D-xylofuranosyl)- $\alpha$ -D-mannopyranoside (**3**).** Prepared from **27** (0.39 g, 0.48 mmol), liquid NH<sub>3</sub> (35 mL), and sodium metal (75 mg, 3.26 mmol) in THF (5 mL) as described for **1**, to afford **3** (0.15 g, 89%) as a foam; *R*<sub>f</sub> 0.48 (85:15, CH<sub>2</sub>Cl<sub>2</sub>/CH<sub>3</sub>OH); [ $\alpha$ ]<sub>D</sub> +109.5 (*c* 0.33, CH<sub>3</sub>OH); <sup>1</sup>H NMR (500 MHz, D<sub>2</sub>O,  $\delta$ <sub>H</sub>) 5.41 (d, 1 H, *J* = 4.4 Hz, H-1'), 4.76 (s, 1 H, H-1), 4.38 (ddd, 1 H, *J* = 5.0, 4.8, 8.4 Hz, H-4'), 4.26 (dd, 1 H, *J* = 4.2, 5.0 Hz, H-3'), 4.21 (dd, 1 H, *J* = 4.4, 4.2 Hz, H-2'), 3.94–3.88 (m, 3 H, H-2, H-4, H-6), 3.83–3.75 (m, 2 H, H-3, H-6), 3.72–3.66 (m, 1 H, H-5), 3.41 (s, 3 H, OCH<sub>3</sub>), 2.80 (dd, 1 H, *J* = 4.8, 13.8 Hz, H-5'), 2.68 (dd, 1 H, *J* = 8.4, 13.8 Hz, H-5'), 2.18 (s, 3 H, SCH<sub>3</sub>); <sup>13</sup>C NMR (125 MHz, D<sub>2</sub>O,  $\delta$ <sub>C</sub>) 105.3 (C-1'), 103.7 (C-1), 80.6 (C-4'), 79.4 (C-2'), 78.4 (C-3'), 76.9 (C-2), 74.0 (C-5), 73.5 (C-3), 73.0 (C-4), 63.9 (C-6), 57.6 (OCH<sub>3</sub>), 35.8 (C-5'), 17.8 (SCH<sub>3</sub>). HRMS (ESI) calcd for (M + Na) C<sub>13</sub>H<sub>24</sub>O<sub>9</sub>S 379.1033, found 379.1032.

**Methyl 2-O-(5-Deoxy-5-methylthio- $\alpha$ -L-xylofuranosyl)- $\alpha$ -D-mannopyranoside (**4**).** Prepared from **29** (25 mg, 0.03 mmol), liquid NH<sub>3</sub> (20 mL), and sodium metal (80 mg) in THF (5 mL) as described for **1**, to afford **4** (8 mg, 63%) as a foam. *R*<sub>f</sub> 0.39 (85:15, CH<sub>2</sub>Cl<sub>2</sub>/CH<sub>3</sub>OH); [ $\alpha$ ]<sub>D</sub> –13.4 (*c* 0.1, CH<sub>3</sub>OH); <sup>1</sup>H NMR (500 MHz, D<sub>2</sub>O,  $\delta$ <sub>H</sub>) 5.25 (d, 1 H, *J* = 4.4 Hz, H-1'), 4.88 (s, 1 H, H-1), 4.47 (ddd, 1 H, *J* = 5.0, 4.9, 8.4 Hz, H-4'), 4.30 (dd, 1 H, *J* = 4.9, 4.2 Hz, H-3'), 4.19 (dd, 1 H, *J* = 4.2, 4.4 Hz, H-2'), 4.05–4.02 (m, 1 H, H-2), 3.88 (dd, 1 H, *J* = 1.9, 12.0 Hz, H-6), 3.83 (dd, 1 H, *J* = 3.5, 9.8 Hz, H-3), 3.80 (dd, 1 H, *J* = 5.0, 12.0 Hz, H-6), 3.70 (dd, 1 H, *J* = 9.8, 9.8 Hz, H-4), 3.65–3.60 (m, 1 H, H-5), 3.41 (s, 3 H, OCH<sub>3</sub>), 2.79 (dd, 1 H, *J* = 5.0, 13.8 Hz, H-5'), 2.68 (dd, 1 H, *J* = 8.4, 13.8 Hz, H-5'), 2.16 (s, 3 H, SCH<sub>3</sub>); <sup>13</sup>C NMR (125 MHz, D<sub>2</sub>O,  $\delta$ <sub>C</sub>) 103.0 (C-1'), 101.4 (C-1), 80.4 (C-4'), 80.0 (C-2'), 79.2 (C-2), 78.3 (C-3'), 75.4 (C-5), 72.8 (C-3), 69.7 (C-4), 63.3 (C-6), 57.7 (OCH<sub>3</sub>), 35.6 (C-5'), 17.7 (SCH<sub>3</sub>). HRMS (ESI) calcd for (M + Na) C<sub>13</sub>H<sub>24</sub>O<sub>9</sub>S 379.1033, found 379.1031.

**Methyl 3-O-(5-Deoxy-5-methylthio- $\alpha$ -L-xylofuranosyl)- $\alpha$ -D-mannopyranoside (5).** Prepared from **31** (32 mg, 0.04 mmol), liquid NH<sub>3</sub> (25 mL), and sodium metal (80 mg) in THF (5 mL) as described for **1**, to afford **5** (9 mg, 65%) as a foam. *R<sub>f</sub>* 0.44 (85:15, CH<sub>2</sub>Cl<sub>2</sub>/CH<sub>3</sub>OH); [ $\alpha$ ]<sub>D</sub> -18.4 (c 0.28, CH<sub>3</sub>OH); <sup>1</sup>H NMR (500 MHz, D<sub>2</sub>O,  $\delta_{\text{H}}$ ) 5.27 (d, 1 H, *J* = 4.4 Hz, H-1'), 4.80 (d, 1 H, *J* = 1.8 Hz, H-1), 4.47 (ddd, 1 H, *J* = 5.2, 5.6, 8.3 Hz, H-4'), 4.31 (dd, 1 H, *J* = 4.6, 5.6 Hz, H-3'), 4.20 (dd, 1 H, *J* = 4.4, 4.6 Hz, H-2'), 4.12–4.10 (dd, 1 H, *J* = 1.8, 3.2 Hz, H-2), 3.94–3.87 (m, 2 H, H-3, H-6), 3.81–3.73 (m, 2 H, H-4, H-6), 3.70–3.64 (m, 1 H, H-5), 3.42 (s, 3 H, OCH<sub>3</sub>), 2.80 (dd, 1 H, *J* = 5.2, 13.8 Hz, H-5'), 2.68 (dd, 1 H, *J* = 8.3, 13.8 Hz, H-5'), 2.16 (s, 3 H, SCH<sub>3</sub>); <sup>13</sup>C NMR (125 MHz, D<sub>2</sub>O,  $\delta_{\text{C}}$ ) 103.4 (C-1'), 101.3 (C-1), 80.2(4) (C-4'), 80.2(1) (C-2'), 79.6 (C-2), 78.4 (C-3'), 75.3 (C-5), 67.9(9) (C-3), 67.9(8) (C-4), 63.8 (C-6), 57.6 (OCH<sub>3</sub>), 35.7 (C-5'), 17.7 (SCH<sub>3</sub>). HRMS (ESI) calcd for (M + Na) C<sub>13</sub>H<sub>24</sub>O<sub>9</sub>S 379.1033, found 379.1031.

**Methyl 4-O-(5-Deoxy-5-methylthio- $\alpha$ -L-xylofuranosyl)- $\alpha$ -D-mannopyranoside (6).** Prepared from **33** (32 mg, 0.04 mmol), liquid NH<sub>3</sub> (30 mL), and sodium metal (90 mg) in THF (5 mL) as described for **1**, to afford **6** (9 mg, 67%) as a foam. *R<sub>f</sub>* 0.5 (85:15, CH<sub>2</sub>Cl<sub>2</sub>/CH<sub>3</sub>OH); [ $\alpha$ ]<sub>D</sub> +1.3 (c 0.5, CH<sub>3</sub>OH); <sup>1</sup>H NMR (500 MHz, D<sub>2</sub>O,  $\delta_{\text{H}}$ ) 5.21 (d, 1 H, *J* = 4.4 Hz, H-1'), 4.77 (d, 1 H, *J* = 1.8 Hz, H-1), 4.47 (ddd, 1 H, *J* = 5.2, 4.9, 8.6 Hz, H-4'), 4.28 (dd, 1 H, *J* = 5.2, 4.6 Hz, H-3'), 4.20 (dd, 1 H, *J* = 4.6, 4.4 Hz, H-2'), 3.99 (dd, 1 H, *J* = 5.8, 3.4 Hz, H-2), 3.90–3.86 (m, 2 H, H-3, H-6), 3.85–3.76 (m, 2 H, H-4, H-6), 3.75–3.71 (m, 1 H, H-5), 3.41 (s, 3 H, OCH<sub>3</sub>), 2.80 (dd, 1 H, *J* = 4.9, 13.8 Hz, H-5'), 2.68 (dd, 1 H, *J* = 8.6, 13.8 Hz, H-5'), 2.16 (s, 3 H, SCH<sub>3</sub>); <sup>13</sup>C NMR (125 MHz, D<sub>2</sub>O,  $\delta_{\text{C}}$ ) 104.6 (C-1'), 103.6 (C-1), 80.3 (C-4'), 79.6 (C-2'), 78.6 (C-2), 78.2 (C-3'), 74.1 (C-5), 72.7 (C-3), 72.1 (C-4), 63.3 (C-6), 57.7 (OCH<sub>3</sub>), 35.8 (C-5'), 17.8 (SCH<sub>3</sub>). HRMS (ESI) calcd for (M + Na) C<sub>13</sub>H<sub>24</sub>O<sub>9</sub>S 379.1033, found 379.1034.

***p*-Tolyl 2,3-Di-*O*-benzyl-5-*O*-toluenesulfonyl-1-thio- $\beta$ -D-xylofuranoside (7).** To a solution of **15** (1.1 g, 2.52 mmol) in pyridine (6 mL) at 0 °C was added toluenesulfonyl chloride (0.625 g, 3.28 mmol). The reaction mixture was stirred at rt for 12 h and then poured into ice water (40 mL) and extracted with CH<sub>2</sub>Cl<sub>2</sub> (2 × 40 mL). The combined CH<sub>2</sub>Cl<sub>2</sub> extracts were washed with 7% aq. CuSO<sub>4</sub> solution (3 × 75 mL) and water (1 × 75 mL) and then dried (Na<sub>2</sub>SO<sub>4</sub>) and concentrated to a syrup that was purified by column chromatography (12:1, hexanes/EtOAc) to afford **7** (1.29 g, 87%) as a syrup. *R<sub>f</sub>* 0.38 (4:1, hexanes/EtOAc); [ $\alpha$ ]<sub>D</sub> -70.9 (c 1.0, CHCl<sub>3</sub>); <sup>1</sup>H NMR (500 MHz, CDCl<sub>3</sub>,  $\delta_{\text{H}}$ ) 7.80–7.75 (m, 2 H), 7.40–7.20 (m, 14 H), 7.10–7.05 (m, 2 H), 5.25 (d, 1 H, *J* = 2.8 Hz), 4.56 (d, 1 H, *J* = 11.8 Hz), 4.48 (dd, 2 H, *J* = 8.8, 11.8 Hz), 4.41–4.34 (m, 3 H), 4.32–4.25 (m, 1 H), 4.07–4.02 (m, 2 H), 2.40 (s, 3 H), 2.32 (s, 3 H); <sup>13</sup>C NMR (125 MHz, CDCl<sub>3</sub>,  $\delta_{\text{C}}$ ) 144.7, 137.5, 137.2, 137.1, 132.8, 131.9 (2 C), 130.9, 129.8 (2 C), 129.7 (2 C), 128.5 (2 C), 128.4(7) (2 C), 128.1, 128.0 (2 C), 127.8 (5 C), 90.8, 86.2, 81.4, 79.2, 72.1 (2 C), 68.2, 21.6, 21.1. HRMS (ESI) calcd for (M + Na) C<sub>33</sub>H<sub>34</sub>O<sub>6</sub>S<sub>2</sub> 613.1689, found 613.1690.

***p*-Tolyl 2,3-Di-*O*-benzyl-5-*O*-toluenesulfonyl-1-thio- $\beta$ -L-xylofuranoside (8).** Prepared from **21** (0.9 g, 2.06 mmol) and toluenesulfonyl chloride (0.51 g, 2.68 mmol) in pyridine (6 mL) as described for **7**, to afford **8** (0.936 g, 77%) as a syrup. *R<sub>f</sub>* 0.38 (4:1, hexanes/EtOAc); [ $\alpha$ ]<sub>D</sub> +67.8 (c 1.0, CHCl<sub>3</sub>); <sup>1</sup>H NMR (500 MHz, CDCl<sub>3</sub>,  $\delta_{\text{H}}$ ) 7.80–7.75 (m, 2 H), 7.40–7.20 (m, 14 H), 7.10–7.05 (m, 2 H), 5.25 (d, 1 H, *J* = 2.8 Hz), 4.56 (d, 1 H, *J* = 11.8 Hz), 4.48 (dd, 2 H, *J* = 8.8, 11.8 Hz), 4.41–4.34 (m, 3 H), 4.32–4.25 (m, 1 H), 4.07–4.02 (m, 2 H), 2.40 (s, 3 H), 2.32 (s, 3 H); <sup>13</sup>C NMR (125 MHz, CDCl<sub>3</sub>,  $\delta_{\text{C}}$ ) 144.7, 137.5, 137.2, 137.1, 132.8, 131.9 (2 C), 130.9, 129.8 (2 C), 129.7 (2 C), 128.5(2) (2 C), 128.4(7) (2 C), 128.1, 128.0, 127.9(6), 127.8 (5 C), 90.8, 86.2, 81.4, 79.2, 72.1 (2 C), 68.2, 21.6, 21.1. HRMS (ESI) calcd for (M + Na) C<sub>33</sub>H<sub>34</sub>O<sub>6</sub>S<sub>2</sub>: 613.1689, found 613.1691.

***p*-Tolyl 5-*O*-Trityl-1-thio- $\beta$ -D-xylofuranoside (13).** To a solution of **12**<sup>30</sup> (1.2 g, 4.67 mmol) in pyridine (8 mL) at rt was added DMAP (0.183 g, 1.5 mmol) followed by trityl chloride (1.63 g, 5.84 mmol). The reaction mixture was stirred at 45 °C for 14 h and then poured

into ice water (30 mL) and extracted with CH<sub>2</sub>Cl<sub>2</sub> (2 × 30 mL). The combined CH<sub>2</sub>Cl<sub>2</sub> extracts were washed with 7% aq. CuSO<sub>4</sub> solution (3 × 75 mL) and water (1 × 75 mL) and then dried (Na<sub>2</sub>SO<sub>4</sub>) and concentrated to a syrup that was purified by column chromatography (4:1, hexanes/EtOAc) to afford **13** (2.12 g, 91%) as a syrup. *R<sub>f</sub>* 0.5 (1:1, hexanes/EtOAc); [ $\alpha$ ]<sub>D</sub> -81.6 (c 1.0, CHCl<sub>3</sub>); <sup>1</sup>H NMR (500 MHz, CDCl<sub>3</sub>,  $\delta_{\text{H}}$ ) 7.53–7.40 (m, 8 H), 7.35–7.20 (m, 9 H), 7.10–7.14 (m, 2 H), 5.23 (d, 1 H, *J* = 3.7 Hz), 4.34–4.28 (m, 2 H), 4.19 (dd, 1 H, *J* = 3.0, 5.1 Hz), 3.51 (dd, 1 H, *J* = 4.6, 10.4 Hz), 3.32–3.27 (m, 2 H), 2.33 (s, 3 H); <sup>13</sup>C NMR (125 MHz, CDCl<sub>3</sub>,  $\delta_{\text{C}}$ ) 143.4 (3 C), 137.7, 132.3 (3 C), 130.6, 129.8 (3 C), 128.6 (4 C), 128.0 (4 C), 127.2 (3 C), 91.4 (87 C), 80.2, 80.2, 78.1, 62.9, 21.1. HRMS (ESI) calcd for (M + Na) C<sub>31</sub>H<sub>30</sub>O<sub>4</sub>S 521.1757, found 521.1758.

***p*-Tolyl 2,3-Di-*O*-benzyl-5-*O*-trityl-1-thio- $\beta$ -D-xylofuranoside (14).** To a solution of **13** (2.0 g, 4.0 mmol) in DMF (8 mL) at 0 °C was added NaH (60% suspension in oil, 0.42 g, 10.42 mmol) in portions. The mixture was stirred for 5 min before benzyl bromide (1.25 mL, 10.5 mmol) was added dropwise. After stirring for 4 h, the reaction mixture was poured into ice water (80 mL) and extracted with CH<sub>2</sub>Cl<sub>2</sub> (2 × 40 mL). The combined CH<sub>2</sub>Cl<sub>2</sub> extracts were washed with water (2 × 40 mL), dried (Na<sub>2</sub>SO<sub>4</sub>), and concentrated to a syrup that was purified by column chromatography (12:1, hexanes/EtOAc) to afford **14** (2.2 g, 81%) as a syrup. *R<sub>f</sub>* 0.46 (5.6:1, hexanes/EtOAc); [ $\alpha$ ]<sub>D</sub> -65.6 (c 1.0, CHCl<sub>3</sub>); <sup>1</sup>H NMR (500 MHz, CDCl<sub>3</sub>,  $\delta_{\text{H}}$ ) 7.50–7.05 (m, 29 H), 5.34 (d, 1 H, *J* = 2.8 Hz), 4.60 (d, 1 H, *J* = 11.9 Hz), 4.52 (d, 1 H, *J* = 12.2 Hz), 4.49 (d, 1 H, *J* = 12.2 Hz), 4.40 (dd, 1 H, *J* = 5.6, 10.6 Hz), 4.32 (d, 1 H, *J* = 12.2 Hz), 4.10 (dd, 1 H, *J* = 1.7, 1.7 Hz), 4.00 (dd, 1 H, *J* = 1.7, 4.5 Hz), 3.60 (dd, 1 H, *J* = 6.4, 9.6 Hz), 3.32 (dd, 1 H, *J* = 5.5, 9.6 Hz), 2.31 (s, 3 H); <sup>13</sup>C NMR (125 MHz, CDCl<sub>3</sub>,  $\delta_{\text{C}}$ ) 144.1 (3 C), 137.7, 137.4, 137.1, 131.7, 131.6 (3 C), 129.6 (2 C), 128.8 (4 C), 128.5 (2 C), 128.3 (2 C), 128.2, 127.9, 127.8(4), 127.8(2), 127.7(4) (4 C), 127.7(2), 127.7, 127.6 (2 C), 127.3, 126.9 (3 C), 90.5, 86.8, 86.8, 81.6, 81.4, 72.0, 71.7, 62.5, 21.1. HRMS (ESI) calcd for (M + Na) C<sub>45</sub>H<sub>42</sub>O<sub>4</sub>S 701.2696, found 701.2698.

***p*-Tolyl 2,3-Di-*O*-benzyl-1-thio- $\beta$ -D-xylofuranoside (15).** To a solution of **14** (2.1 g, 3.09 mmol) in CH<sub>2</sub>Cl<sub>2</sub>/CH<sub>3</sub>OH (7:3, 30 mL) at rt was added *p*-TsOH (40 mg). The mixture was stirred for 15 h, neutralized with Et<sub>3</sub>N, and concentrated to a syrup that was purified by column chromatography (4:1, hexanes/EtOAc) to afford **15** (1.12 g, 83%) as a syrup. *R<sub>f</sub>* 0.21 (4:1, hexanes/EtOAc); [ $\alpha$ ]<sub>D</sub> -82.7 (c 1.0, CHCl<sub>3</sub>); <sup>1</sup>H NMR (500 MHz, CDCl<sub>3</sub>,  $\delta_{\text{H}}$ ) 7.45–7.25 (m, 12 H), 7.15–7.10 (m, 2 H), 5.32 (d, 1 H, *J* = 4.0 Hz), 4.72 (d, 1 H, *J* = 11.8 Hz), 4.60 (d, 1 H, *J* = 11.8 Hz), 4.58 (d, 1 H, *J* = 11.8 Hz), 4.45 (d, 1 H, *J* = 11.8 Hz), 4.27 (dd, 1 H, *J* = 5.2, 10.5 Hz), 4.21–4.16 (m, 2 H), 3.92–3.82 (m, 2 H), 2.33 (s, 3 H); <sup>13</sup>C NMR (125 MHz, CDCl<sub>3</sub>,  $\delta_{\text{C}}$ ) 137.7, 137.4, 137.3, 132.2 (2 C), 130.6, 129.8 (2 C), 128.6 (2 C), 128.5 (2 C), 128.0(2), 128.0(1), 127.9 (2 C), 127.7 (2 C), 90.1, 86.5, 83.0, 81.1, 72.4, 72.2, 61.7, 21.1. HRMS (ESI) calcd for (M + Na) C<sub>26</sub>H<sub>28</sub>O<sub>4</sub>S 459.1600, found 459.1600.

**1,2,3,5-Tetra-*O*-acetyl-L-xylofuranose (16).** L-Xylose (4.17 g, 27.8 mmol), boric acid (3.8 g, 60.7 mmol), and acetic acid (95 mL) were stirred at 50 °C for 1 h before acetic anhydride (95 mL) was added. The mixture was heated at 50 °C for 16 h and then cooled to rt. The boric acid was removed as trimethyl borate by the addition of methanol (20 mL) and in vacuo concentration of the resulting mixture to 100 mL and then the addition of methanol (10 mL) and concentration in vacuo to 50 mL (repeated twice). Acetic anhydride (100 mL) and pyridine (100 mL) were added and the solution was stirred at rt for 2 h. Ice (~250 g) was added, and the mixture was stirred for 1 h and then extracted with CH<sub>2</sub>Cl<sub>2</sub> (3 × 150 mL). The combined CH<sub>2</sub>Cl<sub>2</sub> extracts were washed with 7% aq. CuSO<sub>4</sub> solution (3 × 300 mL) and water (2 × 250 mL) and then dried (Na<sub>2</sub>SO<sub>4</sub>) and concentrated to a syrup that was purified by column chromatography (7:3, hexanes/EtOAc) to afford **16** (7.96 g, 90%,  $\alpha$ : $\beta$ , 1:1.8) as a syrup. *R<sub>f</sub>* 0.2 (7:3, hexanes/EtOAc); <sup>1</sup>H NMR (500 MHz, CDCl<sub>3</sub>,  $\delta_{\text{H}}$ ) 6.42 (d, 0.35 H, *J* = 4.6 Hz), 6.10 (s, 0.65 H), 5.52 (dd, 0.35 H, *J* = 6.5, 6.5 Hz), 5.36

(dd, 0.65 H,  $J = 1.7, 5.6$  Hz), 5.30 (dd, 0.35 H,  $J = 4.6, 6.2$  Hz), 5.20 (d, 0.65 H,  $J = 1.0$  Hz), 4.67–4.60 (m, 1 H), 4.27–4.18 (m, 1.65 H), 4.12 (dd, 0.35 H,  $J = 4.2, 12.2$  Hz), 2.12 (s, 2H), 2.11 (s, 2 H), 2.09 (s, 3 H), 2.07 (s, 3 H), 2.06 (s, 2 H);  $^{13}\text{C}$  NMR (125 MHz,  $\text{CDCl}_3$ ,  $\delta_{\text{C}}$ ) 170.5, 170.3, 169.6, 169.5, 169.3, 169.2, 169.1, 98.8, 92.8, 79.9, 79.4(1), 75.3(9), 75.3, 74.3, 73.8, 62.3, 61.6, 21.0, 20.9, 20.8, 20.7, 20.6, 20.5, 20.4. HRMS (ESI) calcd for (M + Na)  $\text{C}_{13}\text{H}_{18}\text{O}_9$ : 341.0843, found 341.0845.

***p*-Tolyl 2,3,5-Tri-*O*-acetyl-1-thio- $\beta$ -L-xylofuranoside (17).** To a solution of **16** (3.0 g, 9.43 mmol) in  $\text{CH}_2\text{Cl}_2$  (60 mL) at  $-20^\circ\text{C}$  was added *p*-thiocresol (1.29 g, 10.38 mmol) followed by  $\text{BF}_3 \cdot \text{Et}_2\text{O}$  (2.96 mL, 23.58 mmol) dropwise over 6 min. The reaction mixture was stirred at  $-20^\circ\text{C}$  for 6 h, neutralized (at  $-20^\circ\text{C}$ ) with  $\text{Et}_3\text{N}$ , and concentrated to a syrup that was purified by column chromatography (4:1, hexanes/EtOAc) to afford **17** (2.3 g, 75%,  $\beta$ : $\alpha$ , 1:49) as a syrup.  $R_f$  0.37 (7:3, hexanes/EtOAc); data for major isomer;  $[\alpha]_{\text{D}} +83.8$  (c 0.5,  $\text{CHCl}_3$ );  $^1\text{H}$  NMR (400 MHz,  $\text{CDCl}_3$ ,  $\delta_{\text{H}}$ ) 7.44 (d, 2 H,  $J = 8.1$  Hz), 7.14 (d, 2 H,  $J = 8.1$  Hz), 5.30 (dd, 1 H,  $J = 2.2, 5.1$  Hz), 5.26 (dd, 1 H,  $J = 2.2, 3.3$  Hz), 5.18 (d, 1 H,  $J = 3.3$  Hz), 4.45 (ddd, 1 H,  $J = 5.1, 5.1, 6.5$  Hz), 4.32 (dd, 1 H,  $J = 5.1, 11.7$  Hz), 4.24 (dd, 1 H,  $J = 6.5, 11.7$  Hz), 2.33 (s, 3 H), 2.09 (s, 3 H), 2.07 (s, 3 H), 2.05 (s, 3 H);  $^{13}\text{C}$  NMR (100 MHz,  $\text{CDCl}_3$ ,  $\delta_{\text{C}}$ ) 170.5, 169.6, 169.2, 138.2, 133.3 (2 C), 129.7 (2 C), 129.3, 90.2, 80.4, 78.4, 75.2, 62.0, 21.1, 20.8, 20.7, 20.6. HRMS (ESI) calcd for (M + Na)  $\text{C}_{18}\text{H}_{22}\text{O}_7\text{S}$  405.0978, found 405.0977.

***p*-Tolyl 1-Thio- $\beta$ -L-xylofuranoside (18).** To a solution of **17** (2.0 g, 5.24 mmol) in  $\text{CH}_2\text{Cl}_2/\text{CH}_3\text{OH}$  (7:3, 30 mL) was added  $\text{NaOCH}_3$  (0.16 g, 3.0 mmol). The mixture was stirred at room temperature for 7 h and then neutralized with glacial HOAc and concentrated to a syrup that was purified by column chromatography (3:7, hexanes/EtOAc) to afford **18** (1.13 g, 84%) as a syrup;  $R_f$  0.22 (3:7, hexanes/EtOAc);  $[\alpha]_{\text{D}} +151.2$  (c 0.5,  $\text{CH}_3\text{OH}$ );  $^1\text{H}$  NMR (500 MHz,  $\text{CD}_3\text{OD}$ ,  $\delta_{\text{H}}$ ) 7.40 (d, 2 H,  $J = 8.2$  Hz), 7.12 (d, 2 H,  $J = 8.2$  Hz), 5.06 (d, 1 H,  $J = 3.7$  Hz), 4.16–4.10 (m, 2 H), 4.06 (dd, 1 H,  $J = 2.5, 3.7$  Hz), 3.82 (dd, 1 H,  $J = 4.3, 11.5$  Hz), 3.74 (dd, 1 H,  $J = 5.9, 11.5$  Hz), 2.29 (s, 3 H);  $^{13}\text{C}$  NMR (125 MHz,  $\text{CD}_3\text{OD}$ ,  $\delta_{\text{C}}$ ) 138.4, 133.3, 132.7 (2 C), 130.6 (2 C), 93.5, 83.9, 83.5, 77.9, 62.2, 21.1. HRMS (ESI) calcd for (M + Na)  $\text{C}_{12}\text{H}_{16}\text{O}_4\text{S}$  279.0661, found 279.0659.

***p*-Tolyl 5-*O*-Trityl-1-thio- $\beta$ -L-xylofuranoside (19).** Prepared from **18** (1.05 g, 4.09 mmol), DMAP (0.123 g, 1.0 mmol), and trityl chloride (1.425 g, 5.11 mmol) in pyridine (7 mL) as described for **13**, to afford **19** (1.814 g, 89%) as a syrup.  $R_f$  0.5 (1:1, hexanes/EtOAc);  $[\alpha]_{\text{D}} +88.6$  (c 1.0,  $\text{CHCl}_3$ );  $^1\text{H}$  NMR (500 MHz,  $\text{CDCl}_3$ ,  $\delta_{\text{H}}$ ) 7.53–7.40 (m, 8 H), 7.35–7.20 (m, 9 H), 7.10–7.14 (m, 2 H), 5.23 (d, 1 H,  $J = 3.7$  Hz), 4.34–4.28 (m, 2 H), 4.19 (ddd, 1 H,  $J = 3.0, 2.2, 5.2$  Hz), 3.51 (dd, 1 H,  $J = 4.6, 10.4$  Hz), 3.32–3.27 (m, 2 H), 2.33 (s, 3 H);  $^{13}\text{C}$  NMR (125 MHz,  $\text{CDCl}_3$ ,  $\delta_{\text{C}}$ ) 143.4 (3 C), 137.7, 132.3 (3 C), 130.6, 129.8 (3 C), 128.6 (4 C), 128.0 (4 C), 127.2 (3 C), 91.4, 87.6, 82.0, 80.2, 78.1, 62.9, 21.1. HRMS (ESI) calcd for (M + Na)  $\text{C}_{31}\text{H}_{30}\text{O}_4\text{S}$  521.1757, found 521.1753.

***p*-Tolyl 2,3-Di-*O*-benzyl-5-*O*-trityl-1-thio- $\beta$ -L-xylofuranoside (20).** Prepared from **19** (1.8 g, 3.60 mmol), NaH (0.374 g, 9.36 mmol), and benzyl bromide (1.1 mL, 9.36 mmol) in DMF (9 mL) as described for **14**, to afford **20** (1.96 g, 80%) as a syrup.  $R_f$  0.46 (5.6:1, hexanes/EtOAc);  $[\alpha]_{\text{D}} +73.9$  (c 1.2,  $\text{CHCl}_3$ );  $^1\text{H}$  NMR (500 MHz,  $\text{CDCl}_3$ ,  $\delta_{\text{H}}$ ) 7.50–7.05 (m, 29 H), 5.34 (d, 1 H,  $J = 2.8$  Hz), 4.60 (d, 1 H,  $J = 11.9$  Hz), 4.50 (d, 1 H,  $J = 11.9$  Hz), 4.48 (d, 1 H,  $J = 12.2$  Hz), 4.40 (dd, 1 H,  $J = 5.7, 10.6$  Hz), 4.32 (d, 1 H,  $J = 12.2$  Hz), 4.10 (dd, 1 H,  $J = 1.7, 1.7$  Hz), 4.0 (dd, 1 H,  $J = 1.7, 4.5$  Hz), 3.60 (dd, 1 H,  $J = 6.4, 9.6$  Hz), 3.32 (dd, 1 H,  $J = 5.5, 9.6$  Hz), 2.31 (s, 3 H,  $\text{CH}_3$ );  $^{13}\text{C}$  NMR (125 MHz,  $\text{CDCl}_3$ ,  $\delta_{\text{C}}$ ) 144.1 (3 C), 137.7, 137.4, 137.1, 131.7, 131.6 (3 C), 129.6 (2 C), 128.8 (4 C), 128.5 (2 C), 128.2(9) (2 C), 128.2(5), 127.9, 127.8(4), 127.8(2), 127.7(4) (4 C), 127.7(2), 127.7, 127.6 (2 C), 127.3, 126.9 (3 C), 90.5, 86.8, 86.8, 81.6, 81.4, 72.0, 71.7, 62.5, 21.1. HRMS (ESI) calcd for (M + Na)  $\text{C}_{45}\text{H}_{42}\text{O}_4\text{S}$  701.2696, found 701.2695.

***p*-Tolyl 2,3-Di-*O*-benzyl-1-thio- $\beta$ -L-xylofuranoside (21).** Prepared from **20** (1.9 g, 2.80 mmol) and *p*-TsOH (40 mg) in  $\text{CH}_2\text{Cl}_2/\text{CH}_3\text{OH}$  (7:3, 30 mL) as described for **15**, to afford **21** (0.99 g, 81%) as a syrup.  $R_f$  0.21 (4:1, hexanes/EtOAc);  $[\alpha]_{\text{D}} +89.7$  (c 0.5,  $\text{CHCl}_3$ );  $^1\text{H}$  NMR (500 MHz,  $\text{CDCl}_3$ ,  $\delta_{\text{H}}$ ) 7.45–7.25 (m, 12 H), 7.15–7.10 (m, 2 H), 5.32 (d, 1 H,  $J = 4.0$  Hz), 4.72 (d, 1 H,  $J = 11.8$  Hz), 4.60 (d, 1 H,  $J = 11.8$  Hz), 4.58 (d, 1 H,  $J = 11.8$  Hz), 4.45 (d, 1 H,  $J = 11.8$  Hz), 4.27 (dd, 1 H,  $J = 5.2, 10.5$  Hz), 4.21–4.16 (m, 2 H), 3.92–3.82 (m, 2 H), 2.33 (s, 3 H);  $^{13}\text{C}$  NMR (125 MHz,  $\text{CDCl}_3$ ,  $\delta_{\text{C}}$ ) 137.7, 137.4, 137.3, 132.2 (2 C), 130.6, 129.8 (2 C), 128.6 (2 C), 128.5 (2 C), 128.0(2), 128.0(1), 127.9 (2 C), 127.7 (2 C), 90.1, 86.5, 83.0, 81.1, 72.4, 72.2, 61.7, 21.1. HRMS (ESI) calcd for (M + Na)  $\text{C}_{26}\text{H}_{28}\text{O}_4\text{S}$ : 459.1600, found 459.1601.

**Methyl 2-*O*-(2,3-Di-*O*-benzyl-5-*O*-toluenesulfonyl- $\alpha$ -D-xylofuranosyl)-3-*O*-benzyl-4,6-*O*-benzylidene- $\alpha$ -D-mannopyranoside (22).** Thioglycoside **7** (0.21 g, 0.35 mmol) and alcohol **9<sup>29</sup>** (0.11 g, 0.3 mmol) were dried over  $\text{P}_2\text{O}_5$  under a vacuum for 6 h and then dissolved in  $\text{CH}_2\text{Cl}_2$  (4 mL), and the resulting solution was cooled to  $0^\circ\text{C}$ . Powdered 4 Å molecular sieves (75 mg) were added, and the suspension was stirred for 20 min at  $0^\circ\text{C}$  before *N*-iodosuccinimide (96 mg, 0.42 mmol) and silver triflate (16 mg, 0.06 mmol) were added. The reaction mixture was stirred for 15 min, neutralized with  $\text{Et}_3\text{N}$ , diluted with  $\text{CH}_2\text{Cl}_2$  (10 mL), and filtered through Celite. The filtrate was washed successively with saturated aqueous sodium thiosulfate ( $3 \times 15$  mL) and water ( $1 \times 15$  mL) and then dried ( $\text{Na}_2\text{SO}_4$ ) and concentrated to a syrup that was purified by column chromatography (4:1, hexanes/EtOAc) to afford **22** (0.22 g, 91%), as a syrup. The product was an inseparable mixture of isomers ( $\alpha/\beta$ , 87:13), which was used in the next step; data provided for major isomer.  $R_f$  0.49 (7:3, hexanes/EtOAc);  $^1\text{H}$  NMR (500 MHz,  $\text{CDCl}_3$ ,  $\delta_{\text{H}}$ ) 7.77 (d, 2 H,  $J = 8.4$  Hz), 7.50–7.20 (m, 22 H), 5.42 (d, 1 H,  $J = 4.3$  Hz), 5.27 (s, 1 H), 4.88 (d, 1 H,  $J = 11.5$  Hz), 4.82 (d, 1 H,  $J = 11.3$  Hz), 4.69 (d, 1 H,  $J = 11.6$  Hz), 4.64 (d, 1 H,  $J = 1.6$  Hz), 4.64 (d, 1 H,  $J = 12.0$  Hz), 4.48 (d, 1 H,  $J = 11.9$  Hz), 4.46–4.39 (m, 1 H), 4.39–4.33 (m, 2 H), 4.29 (dd, 1 H,  $J = 3.6, 11.0$  Hz), 4.20 (d, 1 H,  $J = 5.4$  Hz), 4.13–4.07 (m, 2 H), 4.07–4.02 (m, 1 H), 3.96 (dd, 1 H,  $J = 3.1, 9.8$  Hz), 3.93 (dd, 1 H,  $J = 4.3, 5.5$  Hz), 3.75 (d, 2 H,  $J = 7.1$  Hz), 3.37 (s, 3 H), 2.43 (s, 3 H);  $^{13}\text{C}$  NMR (125 MHz,  $\text{CDCl}_3$ ,  $\delta_{\text{C}}$ ) 144.7, 138.5, 138.1, 137.8, 137.7, 133.0, 129.7(4), 129.7(0), 128.8, 128.5, 128.3(7) (2 C), 128.3(5) (2 C), 128.3 (2 C), 128.1(8) (2 C), 128.1(5), 128.0, 127.9, 127.8, 127.6(9), 127.6(6), 127.5(9), 127.5(7), 127.5, 126.1, 126.0 (2 C), 101.4, 99.1, 97.5, 84.5, 81.4, 78.4, 74.4(4), 74.4(0), 72.5, 72.1(7), 72.1(5), 71.8, 68.9, 68.8, 64.1, 54.9, 21.6. HRMS (ESI) calcd for (M + Na)  $\text{C}_{47}\text{H}_{50}\text{O}_{12}\text{S}$  861.2915, found 861.2912.

**Methyl 2-*O*-(2,3-Di-*O*-benzyl-5-deoxy-5-methylthio- $\alpha$ -D-xylofuranosyl)-3-*O*-benzyl-4,6-*O*-benzylidene- $\alpha$ -D-mannopyranoside (23).** To a solution of **22** (70 mg, 0.08 mmol) in  $\text{CH}_3\text{CN}$  (2 mL) was added 18-crown-6 (20 mg) followed by sodium thiomethoxide (13 mg, 0.24 mmol). The reaction mixture was heated at reflux for 12 h and then cooled to rt before being diluted with  $\text{CH}_3\text{CN}$  (6 mL) and filtered through Celite. The filtrate was concentrated to a syrup that was purified by column chromatography (5.6:1, hexanes/EtOAc) to afford **23** (42 mg, 70%) as a syrup. The product was an inseparable mixture of isomers ( $\alpha/\beta$ , 87:13), which was used in the next step; data provided for major isomer.  $R_f$  0.39 (4:1, hexanes/EtOAc);  $^1\text{H}$  NMR (400 MHz,  $\text{CDCl}_3$ ,  $\delta_{\text{H}}$ ) 7.55–7.20 (m, 20 H), 5.46 (d, 1 H,  $J = 4.4$  Hz), 5.30 (s, 1 H), 4.90 (d, 1 H,  $J = 9.3$  Hz), 4.87 (d, 1 H,  $J = 9.0$  Hz), 4.75 (d, 1 H,  $J = 1.6$  Hz), 4.70 (dd, 2 H,  $J = 7.5, 11.6$  Hz), 4.54 (d, 1 H,  $J = 11.9$  Hz), 4.48–4.40 (m, 2 H), 4.27 (dd, 2 H,  $J = 4.7, 6.5$  Hz), 4.22–4.16 (m, 2 H), 4.03–3.94 (m, 2 H), 3.78–3.74 (m, 2 H), 3.38 (s, 3 H), 2.85 (dd, 1 H,  $J = 5.1, 13.8$  Hz), 2.70 (dd, 1 H,  $J = 7.9, 13.8$  Hz), 2.16 (s, 3 H);  $^{13}\text{C}$  NMR (125 MHz,  $\text{CDCl}_3$ ,  $\delta_{\text{C}}$ ) 138.6, 138.2, 138.1, 137.7, 128.8, 128.3(3) (3 C), 128.3(2) (3 C), 128.3 (2 C), 128.2 (2 C), 127.7 (4 C), 127.6(1), 127.6(0), 127.5 (2 C), 126.0, 101.7, 101.6, 101.2, 84.1, 82.1, 79.4,

77.3, 76.2, 75.7, 73.7, 72.0, 71.5, 68.7, 63.9, 54.8, 34.1, 16.5. HRMS (ESI) calcd for (M + Na) C<sub>41</sub>H<sub>46</sub>O<sub>9</sub>S 737.2754, found 737.2750.

**Methyl 3-O-(2,3-Di-O-benzyl-5-O-toluenesulfonyl- $\alpha$ -D-xylofuranosyl)-2,4,6-tri-O-benzyl- $\alpha$ -D-mannopyranoside (24).** Prepared from thioglycoside **7** (0.12 g, 0.2 mmol), alcohol **10**<sup>29</sup> (67 mg, 0.14 mmol), *N*-iodosuccinimide (55 mg, 0.24 mmol), and silver triflate (10 mg, 0.04 mmol) in CH<sub>2</sub>Cl<sub>2</sub> (3 mL) as described for **22**, to afford **24** (98 mg, 73%) as a syrup. The product **24** could not be completely purified from ~12% of the  $\beta$ -glycoside and some hydrolyzed donor and hence was used as such for the next step; data provided for major isomer. *R*<sub>f</sub> 0.33 (4:1, hexanes/EtOAc); [ $\alpha$ ]<sub>D</sub> +67.5 (c 0.5, CHCl<sub>3</sub>); <sup>1</sup>H NMR (500 MHz, CDCl<sub>3</sub>,  $\delta$ <sub>H</sub>) 7.20 (d, 2 H, *J* = 8.3 Hz), 7.40–7.14 (m, 25 H), 7.14–7.06 (m, 2 H), 5.20 (d, 1 H, *J* = 4.2 Hz), 4.86 (d, 1 H, *J* = 11.2 Hz), 4.82 (d, 1 H, *J* = 11.6 Hz), 4.76 (d, 1 H, *J* = 1.7 Hz), 4.69 (d, 1 H, *J* = 8.4 Hz), 4.66 (d, 1 H, *J* = 12.0 Hz), 4.60 (d, 1 H, *J* = 12.0 Hz), 4.54 (d, 1 H, *J* = 3.5 Hz), 4.51 (d, 1 H, *J* = 11.3 Hz), 4.42 (d, 1 H, *J* = 11.7 Hz), 4.38 (d, 1 H, *J* = 8.1 Hz), 4.29–4.24 (m, 2 H), 4.18 (dd, 1 H, *J* = 3.6, 10.5 Hz), 4.03 (dd, 2 H, *J* = 3.2, 9.4 Hz), 4.00–3.94 (m, 1 H), 3.88–3.84 (m, 2 H), 3.80–3.70 (m, 3 H), 3.38 (s, 3 H), 2.40 (s, 3 H); <sup>13</sup>C NMR (125 MHz, CDCl<sub>3</sub>,  $\delta$ <sub>C</sub>) 144.6, 138.7, 138.6(9), 138.4, 137.6(0), 137.6, 133.0, 129.7, 128.6, 128.5, 128.4, 128.3(9) (2 C), 128.3(3) (2 C), 128.2(5), 128.2(4) (2 C), 128.2, 128.0, 127.9, 127.8, 127.7, 127.6(4) (2 C), 127.6(3) (2 C), 127.5(9) (2 C), 127.5(7) (2 C), 127.5(5), 127.3(9), 127.3(6), 127.2, 127.0, 101.9, 98.7, 82.8, 81.0, 80.1, 78.0, 74.6, 74.5, 74.4, 73.4, 72.6, 72.5, 72.3, 71.8, 69.4, 69.1, 54.9, 21.6. HRMS (ESI) calcd for (M + Na) C<sub>54</sub>H<sub>58</sub>O<sub>12</sub>S 953.3541, found 953.3541.

**Methyl 3-O-(2,3-Di-O-benzyl-5-deoxy-5-methylthio- $\alpha$ -D-xylofuranosyl)-2,4,6-tri-O-benzyl- $\alpha$ -D-mannopyranoside (25).** Prepared from **24** (40 mg, 0.04 mmol), 18-crown-6 (10 mg), and sodium thiomethoxide (8 mg, 0.12 mmol) in CH<sub>3</sub>CN (1 mL) as described for **23**, to afford **25** (23 mg, 72%) as a syrup. *R*<sub>f</sub> 0.38 (4:1, hexanes/EtOAc); [ $\alpha$ ]<sub>D</sub> +62.1 (c 0.3, CHCl<sub>3</sub>); <sup>1</sup>H NMR (500 MHz, CDCl<sub>3</sub>,  $\delta$ <sub>H</sub>) 7.46–7.10 (m, 25 H), 5.34 (d, 1 H, *J* = 4.1 Hz), 4.85 (d, 2 H, *J* = 12.0 Hz), 4.76 (d, 2 H, *J* = 12.0 Hz), 4.66 (d, 2 H, *J* = 12.0 Hz), 4.62–4.50 (m, 4 H), 4.45 (d, 1 H, *J* = 12.1 Hz), 4.36 (dd, 1 H, *J* = 6.2, 12.6 Hz), 4.23 (dd, 1 H, *J* = 5.2, 5.2 Hz), 4.12 (dd, 1 H, *J* = 3.1, 9.4 Hz), 4.02 (dd, 1 H, *J* = 9.4, 9.4 Hz), 4.00–3.95 (m, 2 H), 3.82–3.70 (m, 3 H), 3.36 (s, 3 H, OCH<sub>3</sub>), 2.75 (dd, 1 H, *J* = 5.6, 13.8 Hz), 2.63 (dd, 1 H, *J* = 7.4, 13.8 Hz, H-5'), 2.08 (s, 3 H, SCH<sub>3</sub>); <sup>13</sup>C NMR (125 MHz, CDCl<sub>3</sub>,  $\delta$ <sub>C</sub>) 138.9, 138.8, 138.4, 138.0, 137.9, 128.4 (2 C), 128.3 (2 C), 128.2(4) (3 C), 128.2(3) (2 C), 127.7, 127.6(8) (2 C), 127.6(4) (3 C), 127.6(3) (2 C), 127.5 (3 C), 127.4, 127.3, 127.2, 127.1 (2 C), 102.2, 99.0, 83.1, 82.0, 79.8, 78.2, 77.7, 74.7, 74.5, 73.4, 72.7, 72.5, 72.4, 71.9, 69.4, 54.8, 34.3, 16.6. HRMS (ESI) calcd for (M + Na) C<sub>48</sub>H<sub>54</sub>O<sub>9</sub>S 829.3380, found 829.3383.

**Methyl 4-O-(2,3-Di-O-benzyl-5-O-toluenesulfonyl- $\alpha$ -D-xylofuranosyl)-2,3,6-tri-O-benzyl- $\alpha$ -D-mannopyranoside (26).** Prepared from thioglycoside **7** (0.76 g, 1.29 mmol), alcohol **11**<sup>29</sup> (0.4 g, 0.86 mmol), *N*-iodosuccinimide (0.35 g, 1.56 mmol), and silver triflate (66 mg, 0.25 mmol) in CH<sub>2</sub>Cl<sub>2</sub> (15 mL) as described for **22**, to afford **26** (0.71 g, 89%) as a syrup. The product was contaminated with ~5% of hydrolyzed **7**, and thus after characterization by NMR, the disaccharide was used directly in the next step. *R*<sub>f</sub> 0.28 (4:1, hexanes/EtOAc); <sup>1</sup>H NMR (500 MHz, CDCl<sub>3</sub>,  $\delta$ <sub>H</sub>) 7.69 (d, 2 H, *J* = 8.3 Hz), 7.40–7.10 (m, 25 H), 7.05–7.00 (m, 2 H), 5.41 (d, 1 H, *J* = 4.3 Hz), 4.83 (s, 1 H), 4.72 (d, 1 H, *J* = 12.4 Hz), 4.65 (d, 1 H, *J* = 12.2 Hz), 4.62–4.53 (m, 3 H), 4.50–4.44 (m, 2 H), 4.38–4.34 (m, 2 H), 4.16 (d, 1 H, *J* = 12.0 Hz), 4.13–3.98 (m, 3 H), 3.94–3.82 (m, 5 H), 3.76 (dd, 1 H, *J* = 4.4, 6.7 Hz), 3.66 (dd, 1 H, *J* = 1.5, 10.5 Hz), 3.55 (dd, 1 H, *J* = 7.3, 10.5 Hz), 3.39 (s, 3 H), 2.36 (s, 3 H); <sup>13</sup>C NMR (125 MHz, CDCl<sub>3</sub>,  $\delta$ <sub>C</sub>) 144.6, 138.6, 138.3, 138.1, 137.7, 137.5, 133.0, 129.6 (2 C), 128.4 (2 C), 128.3(4) (2 C), 128.3(0), 128.2(9) (3 C), 128.2, 127.9, 127.8 (2 C), 127.7(4), 127.7(0) (3 C), 127.6(8) (2 C), 127.6 (2 C), 127.5 (2 C), 127.4(3) (2 C), 127.4, 126.8 (2 C), 100.5, 98.4, 82.2, 80.7, 80.1, 74.1,

73.3, 73.1, 72.6, 72.4, 71.9, 71.8, 70.8, 70.5, 69.7, 69.1, 54.8, 21.6. HRMS (ESI) calcd for (M + Na) C<sub>54</sub>H<sub>58</sub>O<sub>12</sub>S 953.3541, found 953.3540.

**Methyl 4-O-(2,3-Di-O-benzyl-5-deoxy-5-methylthio- $\alpha$ -D-xylofuranosyl)-2,3,6-tri-O-benzyl- $\alpha$ -D-mannopyranoside (27).** Prepared from **26** (0.7 g, 0.75 mmol), 18-crown-6 (60 mg), and sodium thiomethoxide (0.16 g, 2.29 mmol) in CH<sub>3</sub>CN (14 mL) as described for **23** to afford **27** (0.46 g, 76%) as a syrup; *R*<sub>f</sub> 0.3 (4:1, hexanes/EtOAc); [ $\alpha$ ]<sub>D</sub> +67.4 (c 0.3, CHCl<sub>3</sub>); <sup>1</sup>H NMR (500 MHz, CDCl<sub>3</sub>,  $\delta$ <sub>H</sub>) 7.40–7.05 (m, 25 H), 5.55 (d, 1 H, *J* = 4.4 Hz), 4.84 (d, 1 H, *J* = 1.7 Hz), 4.74 (d, 1 H, *J* = 12.5 Hz), 4.66 (d, 1 H, *J* = 12.3 Hz), 4.64–4.56 (m, 4 H), 4.54 (d, 1 H, *J* = 11.8 Hz), 4.43 (d, 1 H, *J* = 11.8 Hz), 4.40 (d, 1 H, *J* = 11.8 Hz), 4.22 (d, 1 H, *J* = 12.1 Hz), 4.14 (dd, 1 H, *J* = 9.6, 9.6 Hz), 4.10–4.03 (m, 2 H), 3.97–3.82 (m, 5 H), 3.72 (dd, 1 H, *J* = 7.4, 10.7 Hz), 3.39 (s, 3 H), 2.68 (dd, 1 H, *J* = 4.4, 13.8 Hz), 2.52 (dd, 1 H, *J* = 6.3, 13.8 Hz), 2.06 (s, 3 H); <sup>13</sup>C NMR (125 MHz, CDCl<sub>3</sub>,  $\delta$ <sub>C</sub>) 138.7, 138.3, 138.1(4), 138.1, 137.7, 128.4(3), 128.3(8) (2 C), 128.3 (3 C), 128.2(8), 128.2(4) (2 C), 127.8, 127.7 (2 C), 127.6(7) (2 C), 127.6 (3 C), 127.5(8) (2 C), 127.5 (2 C), 127.4, 127.3, 126.8 (2 C), 100.7, 98.5, 82.5, 81.7, 80.3, 77.2, 73.3, 72.3, 72.5, 72.4, 71.8(9), 71.8(8), 71.0, 70.6, 70.1, 54.8, 34.8, 16.6. HRMS (ESI) calcd for (M + Na) C<sub>48</sub>H<sub>54</sub>O<sub>9</sub>S 829.3380, found 829.3380.

**Methyl 2-O-(2,3-Di-O-benzyl-5-O-toluenesulfonyl- $\alpha$ -L-xylofuranosyl)-3-O-benzyl-4,6-O-benzylidene- $\alpha$ -D-mannopyranoside (28).** Prepared from thioglycoside **8** (0.12 g, 0.2 mmol), alcohol **9**<sup>29</sup> (54 mg, 0.15 mmol), *N*-iodosuccinimide (0.54 g, 0.24 mmol), and silver triflate (10 mg, 0.04 mmol) in CH<sub>2</sub>Cl<sub>2</sub> (3 mL) as described for **22**, to afford **28** (89 mg, 73%) as a syrup. *R*<sub>f</sub> 0.24 (4:1, hexanes/EtOAc); [ $\alpha$ ]<sub>D</sub> –65.6 (c 0.5, CHCl<sub>3</sub>); <sup>1</sup>H NMR (500 MHz, CDCl<sub>3</sub>,  $\delta$ <sub>H</sub>) 7.73 (d, 2 H, *J* = 8.2 Hz), 7.50 (d, 2 H, *J* = 8.2 Hz), 7.45–7.20 (m, 20 H), 5.58 (s, 1 H), 5.08 (d, 1 H, *J* = 4.0 Hz), 4.70 (s, 1 H), 4.64 (s, 1 H), 4.65–4.54 (m, 3 H), 4.50 (d, 1 H, *J* = 11.0 Hz), 4.46 (d, 1 H, *J* = 11.9 Hz), 4.39 (dd, 1 H, *J* = 5.8, 7.2 Hz), 4.25–4.07 (m, 5 H), 4.03 (dd, 1 H, *J* = 4.2, 5.8 Hz), 3.92 (dd, 1 H, *J* = 3.4, 10.0 Hz), 3.80–3.70 (m, 2 H), 3.34 (s, 3 H), 2.39 (s, 3 H); <sup>13</sup>C NMR (125 MHz, CDCl<sub>3</sub>,  $\delta$ <sub>C</sub>) 144.5, 138.5, 137.9, 137.8, 137.7, 133.1, 129.7 (2 C), 128.8, 128.4 (2 C), 128.3(5) (2 C), 128.3 (2 C), 128.1(2) (3 C), 128.1, 127.9 (3 C), 127.7 (2 C), 127.5, 127.5 (2 C), 127.4, 126.1 (2 C), 101.4, 99.1, 97.5, 84.5, 81.4, 78.4, 74.4(4), 74.4, 72.5, 72.1(7), 72.1(5), 71.8, 68.9, 68.8, 64.1, 54.9, 21.6. HRMS (ESI) calcd for (M + Na) C<sub>47</sub>H<sub>50</sub>O<sub>12</sub>S 861.2915, found 861.2911.

**Methyl 2-O-(2,3-Di-O-benzyl-5-deoxy-5-methylthio- $\alpha$ -L-xylofuranosyl)-3-O-benzyl-4,6-O-benzylidene- $\alpha$ -D-mannopyranoside (29).** Prepared from **28** (44 mg, 0.05 mmol), 18-crown-6 (10 mg), and sodium thiomethoxide (10 mg, 0.18 mmol) in CH<sub>3</sub>CN (1 mL) as described for **23**, to afford **29** (25 mg, 71%) as a syrup. *R*<sub>f</sub> 0.33 (4:1, hexanes/EtOAc); [ $\alpha$ ]<sub>D</sub> –54.1 (c 0.3, CHCl<sub>3</sub>); <sup>1</sup>H NMR (500 MHz, CDCl<sub>3</sub>,  $\delta$ <sub>H</sub>) 7.55–7.20 (m, 20 H), 5.58 (s, 1 H), 5.17 (d, 1 H, *J* = 4.2 Hz), 4.82 (d, 1 H, *J* = 12.6 Hz), 4.77 (d, 1 H, *J* = 12.6 Hz), 4.73–4.65 (m, 3 H), 4.64–4.52 (m, 3 H), 4.35 (dd, 1 H, *J* = 5.0, 6.6 Hz), 4.28–4.25 (m, 1 H), 4.24 (dd, 1 H, *J* = 4.0, 9.3 Hz), 4.20 (dd, 1 H, *J* = 9.3, 9.3 Hz), 4.10 (dd, 1 H, *J* = 4.7, 4.7 Hz), 3.95 (dd, 1 H, *J* = 3.4, 10.0 Hz), 3.80–3.70 (m, 2 H), 3.35 (s, 3 H), 2.80 (dd, 1 H, *J* = 5.6, 13.8 Hz), 2.65 (dd, 1 H, *J* = 7.6, 13.8 Hz), 2.02 (s, 3 H); <sup>13</sup>C NMR (125 MHz, CDCl<sub>3</sub>,  $\delta$ <sub>C</sub>) 138.8, 138.2, 138.0, 137.7, 128.8, 128.4 (2 C), 128.3 (2 C), 128.2 (2 C), 128.1 (2 C), 128.0 (2 C), 127.9, 127.6(1), 127.5(5) (2 C), 127.3–(3) (2 C), 127.3, 126.1 (2 C), 101.4, 99.0, 97.5, 84.8, 82.3, 78.6, 76.9, 74.6, 72.4, 72.2, 72.1, 71.9, 68.8, 64.1, 55.0, 34.1, 16.4. HRMS (ESI) calcd for (M + Na) C<sub>41</sub>H<sub>46</sub>O<sub>9</sub>S 737.2754, found 737.2756.

**Methyl 3-O-(2,3-Di-O-benzyl-5-O-toluenesulfonyl- $\alpha$ -L-xylofuranosyl)-2,4,6-tri-O-benzyl- $\alpha$ -D-mannopyranoside (30).** Prepared from thioglycoside **8** (170 mg, 0.29 mmol), alcohol **10**<sup>29</sup> (93 mg, 0.2 mmol), *N*-iodosuccinimide (78 mg, 0.35 mmol), and silver triflate (15 mg, 0.06 mmol) in CH<sub>2</sub>Cl<sub>2</sub> (4 mL) as described for **22**, to afford **30** (150 mg, 82%) as a syrup. The product was contaminated with ~17% of hydrolyzed **8**, and thus after characterization by NMR, the disac-

charide was used directly in the next step.  $R_f$  0.29 (4:1, hexanes/EtOAc);  $^1\text{H NMR}$  (500 MHz,  $\text{CDCl}_3$ ,  $\delta_{\text{H}}$ ) 7.72 (d, 2 H,  $J = 8.4$  Hz), 7.37–7.11 (m, 27 H), 5.14 (d, 1 H,  $J = 4.0$  Hz), 4.81 (d, 1 H,  $J = 2.3$  Hz), 4.80 (d, 1 H,  $J = 11.2$  Hz), 4.72–4.58 (m, 4 H), 4.57–4.38 (m, 6 H), 4.35–4.26 (m, 1 H), 4.24–4.14 (m, 3 H), 4.01 (dd, 1 H,  $J = 5.9$ , 10.6 Hz), 3.95 (dd, 1 H,  $J = 4.0$ , 5.9 Hz), 3.90 (dd, 1 H,  $J = 8.9$ , 8.9 Hz), 3.83 (dd, 1 H,  $J = 2.5$ , 2.5 Hz), 3.74–3.72 (m, 2H), 3.37 (s, 3 H), 2.40 (s, 3 H);  $^{13}\text{C NMR}$  (125 MHz,  $\text{CDCl}_3$ ,  $\delta_{\text{C}}$ ) 144.5, 138.6, 138.5, 138.2, 137.8, 137.7, 133.0, 129.7, 129.7, 128.5, 128.4(0) (2 C), 128.3(7) (3 C), 128.3(1), 128.3(0), 128.2(6) (2 C), 128.9(9), 127.9(5), 127.9 (2 C), 127.8 (2 C), 127.7, 127.6(5), 127.6(2) (2 C), 127.6, 127.5(7) (4 C), 127.4(3), 127.4(2), 98.7, 97.3, 83.2, 81.2, 75.7, 74.9, 74.6, 73.3, 72.6, 72.5, 72.2, 71.7, 69.4, 68.7, 54.9, 21.6. HRMS (ESI) calcd for (M + Na)  $\text{C}_{54}\text{H}_{58}\text{O}_{12}\text{S}$  953.3541, found 953.3545.

**Methyl 3-O-(2,3-Di-O-benzyl-5-deoxy-5-methylthio- $\alpha$ -L-xylofuranosyl)-2,4,6-tri-O-benzyl- $\alpha$ -D-mannopyranoside (31).** Prepared from **30** (40 mg, 0.04 mmol), 18-crown-6 (10 mg), and sodium thiomethoxide (10 mg, 0.18 mmol) in  $\text{CH}_3\text{CN}$  (1 mL) as described for **23**, to afford **31** (24 mg, 70%) as a syrup.  $R_f$  0.28 (4:1, hexanes/EtOAc);  $[\alpha]_{\text{D}} -20.5$  (c 0.3,  $\text{CHCl}_3$ );  $^1\text{H NMR}$  (500 MHz,  $\text{CDCl}_3$ ,  $\delta_{\text{H}}$ ) 7.40–7.20 (m, 25 H), 5.25 (d, 1 H,  $J = 4.1$  Hz), 4.89 (d, 1 H,  $J = 11.1$  Hz), 4.84 (s, 1 H), 4.74 (d, 1 H,  $J = 4.7$  Hz), 4.72 (d, 1 H,  $J = 4.9$  Hz), 4.68 (d, 2 H,  $J = 12.3$  Hz), 4.63–4.45 (m, 5 H), 4.40 (dd, 1 H,  $J = 6.6$ , 12.9 Hz), 4.28–4.24 (m, 1 H), 4.24–4.19 (m, 1 H), 4.04 (dd, 1 H,  $J = 4.1$ , 4.2 Hz), 3.95 (dd, 1 H,  $J = 8.9$ , 8.9 Hz), 3.91–3.86 (m, 1 H), 3.85–3.73 (m, 3 H), 3.37 (s, 3 H), 2.78 (dd, 1 H,  $J = 6.4$ , 13.8 Hz), 2.61 (dd, 1 H,  $J = 6.7$ , 13.8 Hz), 2.00 (s, 3 H);  $^{13}\text{C NMR}$  (125 MHz,  $\text{CDCl}_3$ ,  $\delta_{\text{C}}$ ) 138.7, 138.5, 138.3, 138.1, 138.0, 128.4, 128.3(1) (3 C), 128.2(8) (4 C), 128.2 (2 C), 127.7(8), 127.7(6) (3 C), 127.7 (2 C), 127.6(8) (3 C), 127.6(6) (3 C), 127.6, 127.5(7), 127.4, 98.7, 97.2, 83.7, 82.3, 77.2, 75.4, 74.8, 74.5, 74.3, 73.3, 72.5, 72.4, 72.2, 71.7, 69.5, 54.9, 33.8, 16.3. HRMS (ESI) calcd for (M + Na)  $\text{C}_{48}\text{H}_{54}\text{O}_9\text{S}$  829.3380, found 829.3381.

**Methyl 4-O-(2,3-Di-O-benzyl-5-O-toluenesulfonyl- $\alpha$ -L-xylofuranosyl)-2,3,6-tri-O-benzyl- $\alpha$ -D-mannopyranoside (32).** Prepared from thioglycoside **8** (0.1 g, 0.17 mmol), alcohol **11**<sup>29</sup> (56 mg, 0.12 mmol), *N*-iodosuccinimide (45 mg, 0.2 mmol), and silver triflate (8 mg, 0.03 mmol) in  $\text{CH}_2\text{Cl}_2$  (3 mL) as described for **22**, to afford **32** (8 mg, 71%) as a syrup.  $R_f$  0.29 (4:1, hexanes/EtOAc);  $[\alpha]_{\text{D}} -38.6$  (c 0.5,  $\text{CHCl}_3$ );  $^1\text{H NMR}$  (500 MHz,  $\text{CDCl}_3$ ,  $\delta_{\text{H}}$ ) 7.69 (d, 2 H,  $J = 8.3$  Hz), 7.39–7.11 (m, 27 H), 5.05 (d, 1 H,  $J = 4.1$  Hz), 4.76 (d, 1 H,  $J = 1.9$  Hz), 4.75–4.60 (m, 4 H), 4.55–4.36 (m, 6 H), 4.34–4.20 (m, 3 H), 4.19–4.13 (m, 2 H), 4.10 (dd, 1 H,  $J = 4.1$ , 10.3 Hz), 3.90 (dd, 1 H,  $J = 5.5$ , 10.3 Hz), 3.83 (dd, 1 H,  $J = 3.1$ , 9.0 Hz), 3.80–3.66 (m, 3 H), 3.33 (s, 3 H), 2.36 (s, 3 H);  $^{13}\text{C NMR}$  (125 MHz,  $\text{CDCl}_3$ ,  $\delta_{\text{C}}$ ) 144.4, 138.5, 138.4, 138.3, 137.8, 137.7, 133.0, 129.7, 129.6, 128.5, 128.4 (3 C), 128.3(6), 128.3(2) (2 C), 128.3, 128.2(7), 128.0, 127.9 (2 C), 127.8(6) (2 C), 127.8, 127.7 (4 C), 127.6(4), 127.6(2), 127.5(8) (2 C), 127.5(5), 127.5(3) (2 C), 127.5, 99.4, 99.2, 83.4, 80.8, 78.5, 74.4, 73.9, 73.4, 72.8, 72.7, 72.7, 72.5, 71.9, 71.7, 69.2, 68.7, 54.8, 21.6. HRMS (ESI) calcd for (M + Na)  $\text{C}_{54}\text{H}_{58}\text{O}_{12}\text{S}$  953.3541, found 953.3540.

**Methyl 4-O-(2,3-Di-O-benzyl-5-deoxy-5-methylthio- $\alpha$ -L-xylofuranosyl)-2,3,6-tri-O-benzyl- $\alpha$ -D-mannopyranoside (33).** Prepared from **32** (47 mg, 0.05 mmol), 18-crown-6 (10 mg), and sodium thiomethoxide (10 mg, 0.18 mmol) in  $\text{CH}_3\text{CN}$  (1 mL) as described for **23**, to afford **33** (31 mg, 77%) as a syrup.  $R_f$  0.28 (4:1, hexanes/EtOAc);  $[\alpha]_{\text{D}} -28.8$  (c 0.6,  $\text{CHCl}_3$ );  $^1\text{H NMR}$  (500 MHz,  $\text{CDCl}_3$ ,  $\delta_{\text{H}}$ ) 7.40–7.20 (m, 25 H), 5.19 (d, 1 H,  $J = 4.1$  Hz), 4.78–4.44 (m, 10 H), 4.41–4.34 (m, 2 H), 4.23 (dd, 1 H,  $J = 9.2$ , 9.2 Hz), 4.14 (dd, 1 H,  $J = 6.2$ , 6.2 Hz), 3.92–3.86 (m, 2 H), 3.82–3.68 (m, 4 H), 3.35 (s, 3 H), 2.68 (dd, 1 H,  $J = 5.9$ , 13.8 Hz), 2.52 (dd, 1 H,  $J = 6.7$ , 13.8 Hz), 1.98 (s, 3 H);  $^{13}\text{C NMR}$  (125 MHz,  $\text{CDCl}_3$ ,  $\delta_{\text{C}}$ ) 138.8, 138.5, 138.4, 138.1, 137.9, 128.3(4), 128.3(3) (2 C), 128.2(6) (3 C), 128.2 (2 C), 127.8 (2 C), 127.7(9) (2 C), 127.7(1) (2 C), 127.7 (2 C), 127.6(2) (2 C), 127.5(8), 127.5(5) (2 C), 127.5 (2 C), 127.4(4), 127.4, 99.7, 99.3, 83.9, 81.8,

78.5, 74.8, 73.4, 72.9, 72.7, 72.6(5), 72.6, 72.0, 71.8, 69.5, 54.6, 34.2, 16.4. HRMS (ESI) calcd for (M + Na)  $\text{C}_{48}\text{H}_{54}\text{O}_9\text{S}$  829.3380, found 829.3382.

**Methyl 4-O-(5-Deoxy-5-sulfoxymethyl- $\alpha$ -D-xylofuranosyl)- $\alpha$ -D-mannopyranoside (34).** To a solution of **3** (60 mg, 0.17 mmol) in distilled water (0.3 mL) was added a solution of  $\text{H}_2\text{O}_2$  (30% aq., 0.019 mL). The reaction mixture was stirred for 9 min at rt and then lyophilized. The residue was purified by column chromatography on Iatrobeds (85:15,  $\text{CH}_2\text{Cl}_2/\text{CH}_3\text{OH}$ ) to afford **34** (51 mg, 81%, 1:1 mixture of diastereomers) as a foam.  $R_f$  0.12 (5.6:1,  $\text{CH}_2\text{Cl}_2/\text{CH}_3\text{OH}$ );  $[\alpha]_{\text{D}} +160.4$  (c 0.3,  $\text{CH}_3\text{OH}$ );  $^1\text{H NMR}$  (500 MHz,  $\text{D}_2\text{O}$ ,  $\delta_{\text{H}}$ ) 5.47 (d, 0.5 H,  $J = 4.5$  Hz, H-1'), 5.46 (d, 0.5 H,  $J = 4.4$  Hz, H-1'), 4.76 (s, 1H, H-1), 4.65 (ddd, 0.5 H,  $J = 5.2$ , 4.4, 8.5 Hz, H-4'), 4.62 (ddd, 0.5 H,  $J = 5.2$ , 4.6, 8.5 Hz, H-4'), 4.34 (dd, 1 H,  $J = 5.2$ , 4.5 Hz, H-3'), 4.23 (dd, 1 H,  $J = 4.5$ , 4.5 Hz, H-2'), 4.20 (dd, 1 H,  $J = 4.4$ , 4.5 Hz, H-2'), 3.94–3.85 (m, 3 H, H-2, H-3, H-6), 3.85–3.76 (m, 2 H, H-4, H-6), 3.72–3.66 (m, 1 H, H-5), 3.41 (s, 3 H,  $\text{OCH}_3$ ), 3.29 (dd, 0.5 H,  $J = 4.4$ , 13.9 Hz, H-5'), 3.15–3.10 (m, 1.0 H, H-5'), 3.09 (dd, 0.5 H,  $J = 8.5$ , 13.9 Hz, H-5'), 2.81 (s, 1.5 H,  $\text{S(O)CH}_3$ ), 2.80 (s, 1.5 H,  $\text{S(O)-CH}_3$ );  $^{13}\text{C NMR}$  (125 MHz,  $\text{D}_2\text{O}$ ,  $\delta_{\text{C}}$ ) 105.6 (1 C, C-1'), 103.7 (1 C, C-1), 79.4 (0.5 C, C-2'), 79.1 (0.5 C, C-2'), 78.6(0) (0.5 C, C-3'), 78.5(7) (0.5 C, C-3'), 77.0 (0.5 C, C-2), 76.8 (0.5 C, C-2), 76.4 (0.5 C, C-4'), 75.7 (0.5 C, C-4'), 73.8(7) (0.5 C, C-5), 73.8(5) (0.5 C, C-5), 73.5(1) (0.5 C, C-3), 73.4(9) (0.5 C, C-3), 73.0 (1 C, C-4), 63.7(1) (0.5 C, C-6), 63.6(9) (0.5 C, C-6), 57.6 (1 C,  $\text{OCH}_3$ ), 57.2 (0.5 C, C-5'), 55.7 (0.5 C, C-5'), 40.6 (0.5 C,  $\text{S(O)CH}_3$ ), 40.2 (0.5 C,  $\text{S(O)-CH}_3$ ). HRMS (ESI) calcd for (M + Na)  $\text{C}_{13}\text{H}_{24}\text{O}_{10}\text{S}$  395.0982, found 395.0984.

**PSEUROT Calculations.** All calculations were done with PSEUROT 6.3 following modification of the parameters provided for the xylofuranosyl ring. The electronegativities (in  $\text{D}_2\text{O}$ ) used were as follows: 1.25 for OH; 1.26 for OR; 0.68 for  $\text{CH}_2\text{OH}$ ; 0.62 for CH(OR); 0.0 for H.<sup>52</sup> For each endocyclic torsion angle, the parameters  $\alpha$  and  $\epsilon$  were set to 1 and 0, respectively. To translate the exocyclic H,H torsion angles ( $\Phi_{\text{HH}}$ ) into the endocyclic torsion angles ( $\nu_i$ ) that are used to determine the pseudorotational phase angle ( $P$ ), the program makes use of the relationship:  $\Phi_{\text{HH}} = A\nu_i + B$ . The values of  $A$  and  $B$  used were those previously calculated for the methyl  $\alpha$ -D-xylofuranoside.<sup>53</sup> In all calculations the puckering amplitude,  $\tau_m$ , was kept constant at  $40^\circ$ , the value found in the crystal structure of **35**.<sup>41</sup> These PSEUROT calculations led to the identification of two different solutions, one of which could be eliminated on the basis of the magnitude of the  $^3J_{\text{C-1-H-4}}$  in **36** (0.5 Hz), as described previously.<sup>39</sup>

**Determination of C<sub>4</sub>–C<sub>5</sub> Rotamer Populations.** The rotamer populations about the C<sub>4</sub>–C<sub>5</sub> bond in the furanose residue in **3**, **34**–**36** were determined by analysis of the three bond  $^1\text{H}$ – $^1\text{H}$  coupling constants between H<sub>4</sub> and H<sub>5R</sub> ( $^3J_{4,5R}$ ) and H<sub>4</sub> and H<sub>5S</sub> ( $^3J_{4,5S}$ ) using eqs 1–3, which were derived by taking into account the differences in electronegativities between oxygen and sulfur. In assigning the resonances arising from H<sub>5R</sub> and H<sub>5S</sub>, the assumption was made that the chemical shift of H<sub>5S</sub> is greater than that of H<sub>5R</sub>, which is the case in the parent glycoside, **35**.<sup>54</sup>

$$2.0X_{gg} + 11.5X_{gt} + 3.9X_{tg} = ^3J_{4,5R} \quad (1)$$

$$3.3X_{gg} + 2.6X_{gt} + 11.5X_{tg} = ^3J_{4,5S} \quad (2)$$

$$X_{gg} + X_{gt} + X_{tg} = 1 \quad (3)$$

The results of these analyses were compared with the rotamer populations found in **35**, which were calculated using eqs 4–6.

$$1.1X_{gg} + 10.8X_{gt} + 4.2X_{tg} = ^3J_{4,5R} \quad (4)$$

$$2.4X_{gg} + 2.9X_{gt} + 10.8X_{tg} = ^3J_{4,5S} \quad (5)$$

$$X_{gg} + X_{gt} + X_{tg} = 1 \quad (6)$$

The coefficients for eqs 1, 2, 4, and 5 were determined by calculating the limiting  ${}^3J_{\text{H,H}}$  for each rotamer using eq 7.<sup>52</sup>

$${}^3J_{\text{H,H}} = 14.63 \cos^2 \theta - 0.78 \cos \theta + 0.60 + \sum_i [0.34 - 2.31 \cos^2 (\xi_i \theta + 18.4 \chi \chi \chi)] \chi_i \quad (7)$$

For eq 7,  $\chi_i$  is the group electronegativity<sup>52</sup> of the substituents along the coupling pathway and  $\xi_i = +1$  or  $-1$  as previously defined.<sup>55</sup> The electronegativities used are as follows: 1.25 for OH; 1.26 for OR; 0.70 for SCH<sub>3</sub>, and 0.0 for H. The angles  $\theta$  used in eq 7 were those of the idealized staggered conformers (60°, -60°, and 180°).

**Cytokine Induction Assays.** THP-1 cells were resuspended at a concentration of  $1 \times 10^6$  cells/mL in RPMI 1640 + 10% FCS + 1% GPS (200 mM penicillin/streptomycin (Sigma UK) + 2 mM l-glutamine

(Invitrogen)) and plated into a 48-well plate (500  $\mu\text{L}$ /well). Cells were treated with either **3** or **34** (100  $\mu\text{g}$  and 10  $\mu\text{g}/\text{mL}$ ) or AraLAM or ManLAM (10  $\mu\text{g}/\text{mL}$ ) for 24 h and then stimulated for a further 8 h with a combination of *Staphylococcus aureus* Cowan (SAC) (Pansorb-inTM, Calbiochem, UK) and human IFN $\gamma$  (1000 U/mL, Preprotech). Following incubation, the supernatants were collected and stored in 200  $\mu\text{L}$  aliquots ( $-80^\circ\text{C}$ ) and analyzed by ELISA (R&D systems) for IL-12p70 and TNF- $\alpha$  production.

**Acknowledgment.** This work was supported by the University of Alberta, The Natural Sciences and Engineering Research Council of Canada, and the Alberta Ingenuity Centre for Carbohydrate Science. G.S.B. and D.A.L. acknowledge support from the Medical Research Council (G9901077 and G0500590). G.S.B. acknowledges support as a Lister-Jenner Research Fellow.

**Supporting Information Available:**  ${}^1\text{H}$  and  ${}^{13}\text{C}$  NMR spectra of all previously unreported compounds, and details on the synthesis of **36**. This material is available free of charge via the Internet at <http://pubs.acs.org>.

JA057373Q

- (52) Altona, C.; Francke, R.; de Haan, R.; Ippel, J. H.; Daalmans, G. J.; Westra Hoekzema, A. J. A.; van Wijk, J. *Magn. Reson. Chem.* **1994**, *32*, 670–678.  
(53) Houseknecht J. B.; Altona, C.; Hadad, C. M.; Lowary, T. L. *J. Org. Chem.* **2002**, *67*, 4647–4651.  
(54) Serianni, A. S.; Barker, R. *Can. J. Chem.* **1979**, *57*, 3160–3167.  
(55) Haasnoot, C. A. G.; de Leeuw, F. A. A. M.; de Leeuw, H. P. M.; Altona, C. *Recl. Trav. Chim. Pays-Bas* **1979**, *98*, 576–577.